

DURISOL WALL FORM SYSTEM

TECHNICAL AND
INSTALLATION GUIDE

Updated:

May 2007

TABLE OF CONTENTS

TABLE OF CONTENTS	i
LIST OF FIGURES	ii
LIST OF TABLES	iii
PHOTOGRAPHIC RECORDS	iii
WARRANTY	iv
DISCLAIMER	iv
1.0 SYSTEM OVERVIEW	1
1.1 Durisol Wall Forms	1
1.2 Applications	2
1.3 Performance Advantages	2
1.3.1 Impact Resistance	2
1.3.2 Improved Indoor Air Quality	2
1.3.3 Sound Protection	3
1.3.4 Thermal Mass effect	4
1.3.5 Negligible Thermal Bridging	4
1.3.6 Fire Resistance	5
1.3.7 Moisture Protection	5
1.3.8 Termite Resistance	6
1.4 Construction Advantages	6
1.5 Design Flexibility	7
1.6 Research and Testing	7
1.7 Standard Wall Forms (Imperial)	8
1.8 Standard Wall Forms (SI)	9
1.9 Thermal Wall Forms (Imperial)	10
1.10 Thermal Wall Forms (SI)	11
1.11 Wall System Summary	12
2.0 INSTALLATION	13
2.1 Modular Planning and Design	13
2.2 Footings and Slabs-on-Grade	13
2.3 Wall Layout	14
2.4 Material Unloading and Placement	14
2.5 Placement of First Course	14
2.6 Placement of Subsequent Courses	15
2.7 Reinforcement	15
2.7.1 Horizontal Reinforcing	15
2.7.2 Vertical Reinforcing	17
2.8 Door and Window Openings	17
2.9 Reinforcement at Door and Window Openings	23
2.10 T-Walls and Pilasters	23

TABLE OF CONTENTS

2.11 Non 90° Corners	25
2.12 Wall Alignment and Bracing.....	26
2.13 Electrical Services and Wall Penetrations	29
2.14 Concrete Placement	30
3.0 INTERIOR FINISHES	32
3.1 Gypsum Board	32
3.2 Interior Plaster/Stucco.....	33
3.3 Other Interior Finishes	33
4.0 EXTERIOR FINISHES	34
4.1 Below-Grade Waterproofing	34
4.2 Above-Grade Finishes	35
4.2.1 Acrylic based coatings.....	35
4.2.2 Traditional non-acrylic stucco	35
4.2.3 Masonry Veneer	38
4.2.4 Siding.....	42
5.0 AIR-VAPOUR BARRIER REQUIREMENTS.....	45

LIST OF FIGURES

Figure 1.1 – Wall Form System Overview	1
Figure 1.2 – Standard Wall Form Schematic.....	8
Figure 1.3 – Standard Wall Form Schematic (SI)	9
Figure 1.4 – Thermal Wall Form Schematic	10
Figure 1.5 – Thermal Wall Form Schematic (SI).....	11
Figure 2.1 – Typical Step Footing	13
Figure 2.2 – Typical Reinforcement Placement	16
Figure 2.3 – Window Opening and Buck Detail	18
Figure 2.4 – Window Buck at Jamb Detail 1	19
Figure 2.5 – Window Buck at Jamb Detail 2	20
Figure 2.6 – Window Buck Detail at Durisol Lintel.....	21
Figure 2.7 – Window Buck Detail at Non-Durisol Lintel	22
Figure 2.8 – T-Wall Construction	24
Figure 2.9 – Non-90° Corners	25
Figure 2.10 – Durisol Wall Alignment Wedges	27
Figure 2.11 – Durisol Wall Alignment / Bracing System	28
Figure 2.12 – Electrical Service Installation	29
Figure 4.1 – Masonry Veneer Detail 1	39
Figure 4.2 – Masonry Veneer Detail 2	40
Figure 4.3 – Masonry Veneer Detail 3	41

TABLE OF CONTENTS

Figure 4.4 – Strapping Attachment Plates	43
Figure 4.5 – Siding Attachment Detail	44

LIST OF TABLES

Table 1.1 – Building Material Off-Gas Test Results.....	3
Table 1.2 – STC Rating of Typical Durisol Wall Systems.....	3
Table 1.3 – Thermal Bridging Effects of Durisol vs. Conventional Wall Construction	5
Table 1.4 – Termite Resistance of Durisol.....	6
Table 1.5 – Standard Wall Form Dimensions (Imperial).....	8
Table 1.6 – Standard Wall Form Dimensions (SI)	9
Table 1.7 – Thermal Wall Form Dimensions (Imperial)	10
Table 1.8 – Thermal Wall Form Dimensions (SI).....	11
Table 1.9 – Wall Form Types and Availability (Nominal Dimensions)	12
Table 1.10 – Wall System Summary.....	12
Table 3.1 – Fastener Types and Pull-out Loads.....	32

PHOTOGRAPHIC RECORDS

1. Typical Projects.....	48
2. Construction Photographs	55

WARRANTY

We warranty our products to be free of defects and manufactured to meet published physical properties when cured and tested according to ASTM, CSA and Durisol Standards.

Under this warranty, Durisol will provide replacement product for any Durisol Wall Form proven to be defective when applied in accordance with written instructions and in applications recommended by Durisol for this product.

All claims must be made within 1 (one) year of shipment. Absence of such claim in writing during this period will constitute a waiver of all claims with respect of such products.

This warranty is in lieu of any and all other warranties expressed and implied.

DISCLAIMER

The recommendations, suggestions, statements and technical data in this technical guide are based on Durisol's best knowledge. ***They are given for informational purposes only and are not to be construed as overriding any requirements of any applicable building code.***

Durisol Building Systems Inc. has no control over installation, workmanship, inspection, building conditions or applications. There is no responsibility, expressed or implied warranty, either as to merchantability or fitness for the particular purpose, made as to the performance or results of an installation using Durisol Wall Forms.

Structures built with the Durisol Wall Forms should be designed and constructed in accordance with applicable building codes. ***Durisol material is not designed to carry any structural load other than temporary concrete pressures that occur during construction.*** The concrete core within the Wall Form is intended to be the primary load carrying material of the wall system. The design of the Durisol wall system should be conducted and reviewed by an engineer.

Durisol material is not designed to prevent the penetration of moisture through the wall system. The design of the Durisol wall system should be conducted and reviewed by a design professional to ensure there is a properly designed weather barrier with adequate flashing to prevent the penetration of moisture through the wall and into the interior.

This document is not intended to override any applicable codes and practices that may be required in local jurisdictions. The user should refer to applicable building code requirements when exceeding the limitations of this document, when requirements conflict with the building code, or when an engineered design is specified. This specification is not intended to limit the appropriate use of concrete or construction not specifically prescribed. This document is also not intended to restrict the use of sound judgment or exact engineering analysis of specific applications that may result in designs with improved performance and economy.

1.0 SYSTEM OVERVIEW

The Durisol Wall System is a proven method of constructing modular insulated concrete walls with over 50 years of in-place experience. It is based on simple interlocking wall form units that are made from the unique Durisol material. Durisol is a proprietary material that is composed of only natural raw materials; specially graded wood chips (100% natural lumber) and Portland cement. We do not use polystyrene, foams, plastics or other potentially detrimental materials in the manufacture of our products.

The wood chips are mineralized and bonded under pressure with Portland cement. The resulting lightweight, open-textured product is highly durable, practically incombustible and resistant to insects and rot.

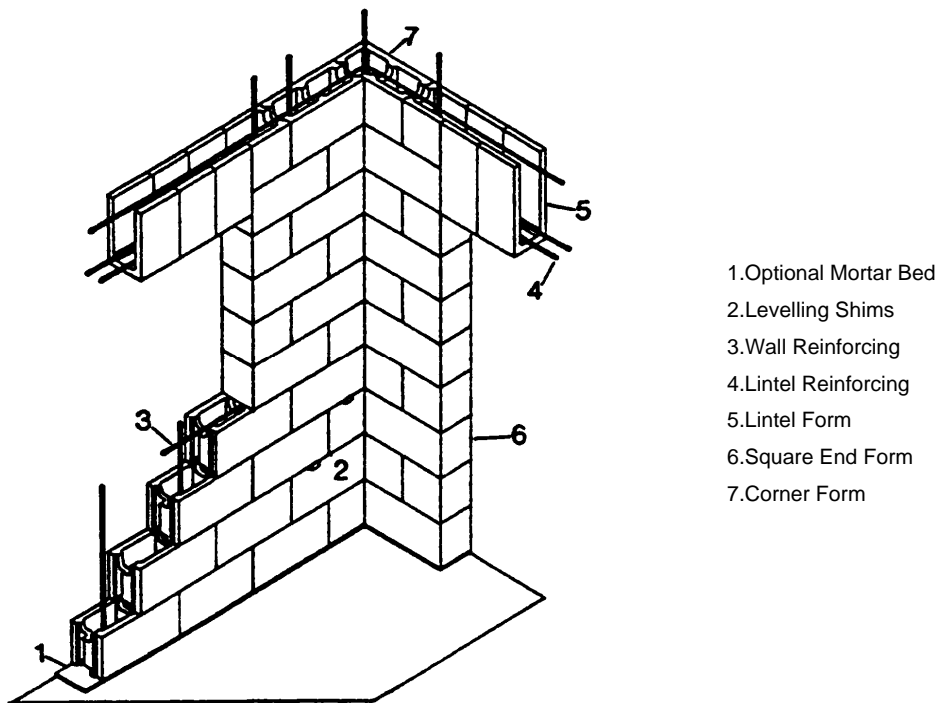

Figure 1.1 – Wall Form System Overview

1.1 Durisol Wall Forms

The Wall Form units are approximately 12” high x 36” long and come in various widths. The units are dry-stacked and filled with concrete and reinforcing steel. This efficient method of concrete construction results in a wall that has built-in thermal, fire and acoustic protection.

The standard Non-thermal Wall Form unit has an insulation value of R8. Additional insulation inserts made from various materials may also be incorporated directly within the Wall Form at the time of manufacturing. Currently the most common type of insert is made from mineral fibre insulation, which can provide for insulation values that range from R14 to R28+, depending on the specific application.

1.2 Applications

Durisol Wall Forms have been used worldwide in every possible building application both above and below-grade. In our 50-year history of Durisol Wall Forms, wall systems have been constructed for use in the following:

- Residential (Single and Multi-Unit)
- Industrial
- Agricultural
- Commercial
- Institutional
- High Rise (Over 26 story buildings in-place)

Durisol Wall Forms have been designed to accommodate all practical ranges of concrete thickness. The load carrying capacity of the wall system depends entirely upon the thickness of the concrete core and the steel reinforcing schedule.

The 4-hour Fire Resistance Rating of the 8" Wall Form makes the Durisol wall system ideal for use as a party wall or common wall between residential units. The high Sound Transmission Class Rating (STC) of over 52 provides for quiet living in apartments or next to highways, railroad tracks, airports and other loud environments.

1.3 Performance Advantages

The Durisol Wall System has a unique combination of desirable properties. In-service advantages are outlined as follows:

1.3.1 IMPACT RESISTANCE

Standard stuccos applied directly to the Durisol material result in a finish that is less expensive and more impact resistant than conventional EIFS systems (polystyrene, lath and stucco).

1.3.2 IMPROVED INDOOR AIR QUALITY

The cement content of the Durisol material creates an above average pH environment at the wall surface, which inhibits the growth of fungi and viruses. The Durisol material is completely inert with no VOCs or off-gasing. Furthermore, the hygroscopic nature of the material moderates RH level. This regulation of water vapour keeps humidity low and further serves to repress any type

of fungal growth. The following table summarizes the levels of VOCs that are emitted by various construction materials:

Table 1.1 – Building Material Off-Gas Test Results

Material	TVOCs ($\mu\text{g}/\text{m}^2 \cdot \text{h}$)	Water Extract Formaldehyde ($\mu\text{g}/\text{g}$)
Isocyanurate Foam	< 1	< 2
Glass Fiber Batt	3.6	200
Durisol	< 10	4
Drywall	20	8
Concrete Block	26	< 1
Polystyrene	280	< 2
Laminate / Particle Board	590	420

Notes:

1. Test conducted by Ortech as part of report submitted to Canada Mortgage and Housing Corp for Build Green Program (1995).

1.3.3 SOUND PROTECTION

Durisol wall systems provide considerable protection against unwanted noise. The sound absorptive properties of our material in combination with the mass of the wall system can provide an ideal combination of sound absorption and sound transmission properties. STC ratings for Durisol wall systems can range between 52 and 68, while the exposed surface of the Durisol Wall Form can provide Noise Reduction Coefficient (NRC) ratings as high as 1.0.

Table 1.2 – STC Rating of Typical Durisol Wall Systems

Wall System	STC Rating
WF20 (8") + plaster / EIFS	52
WF20 (8") + plaster/stucco	56
WF25 (10") + plaster/stucco	64
WF30 (12") + plaster/stucco	68

Notes:

2. Higher STC ratings are possible by altering wall configurations.
3. Test Reports are available upon request.

1.3.4 THERMAL MASS EFFECT

Materials like concrete, brick, and Durisol have a high heat capacity; that is, they can store a significant amount of heat energy. This benefit of thermal mass, as the ability to store heat is called, results in reduced heating costs as the energy/heat in the wall is transferred back into the cooler air. Similarly, when the surrounding air is warmer than the walls, heat will be transferred to the thermal mass and reduce cooling energy consumption. The benefits of thermal mass are increased through the use of Durisol Wall Forms since the majority of the insulation is located on the exterior face of the wall system. This is unlike foam concrete forms that have 50% of the insulation on the interior face and reduce the net benefit that is obtained through the effects of thermal mass.

The true benefit that is realized from thermal mass effects depends on a number of site-specific parameters such as climatic conditions and building orientation. Simple blanket statements such as “R-40 when including thermal mass” are inaccurate and misleading. Durisol Building Systems has a staff of engineers experienced in the field of Building Science who will provide customers with detailed evaluation of thermal mass effects upon request. Alternately, publications such as [ASHRAE Fundamentals](#) or [ASHRAE Standard 90.1](#) will provide guidance to evaluation of different wall systems and corresponding dynamic effects.

1.3.5 NEGLIGIBLE THERMAL BRIDGING

Durisol and framed wall systems are not simple one-dimensional assemblies. Real buildings are three-dimensional, with corners, window openings, etc. However, most wall R-value calculation methods, and almost all marketing brochures, do not factor in the effects of framing at windows, doors, corners, etc. Thus they tend to over-estimate the true thermal performance.

The construction details that increase heat flow through a framed wall system have little or no influence on the heat flow through the Durisol Insulated Wall Form System. Durisol Wall Forms are designed to ensure that the R-value through the core of the wall is almost the same as that through the web. This not only avoids thermal short-circuiting, it ensures uniform wall temperatures with no cold spots to encourage condensation, create discomfort, or cause dust marking.

Recent studies by Oakridge National Labs, ASHRAE 90.1 committee and other independent research agencies have shown how these factors influence the overall performance of wall systems (see following table).

Table 1.3 – Thermal Bridging Effects of Durisol vs. Conventional Wall Construction

Wall Type	Nominal R-value	Whole Wall R-value
2x6 (24" o/c) wood stud with R-19 batt insulation	R-20	R-13.7
2x4 (24" o/c) metal studs with R-11 batt insulation + 1" continuous EPS on exterior	R-17	R-10.2
Durisol WF30 T3 (12" R-20)	R-20	R-19.8

Notes:

1. The above Whole Wall insulation value considers thermal bridging effects only.
2. Mass effects will further increase the relative performance of Durisol and other mass wall systems.
3. Contact Durisol for detailed evaluation of dynamic thermal performance.

1.3.6 FIRE RESISTANCE

The fire resistant properties of Durisol itself and the Durisol wall system as a whole provide considerable protection from fires. Tests in Canada have been conducted for two and four-hour fire ratings while in Austria, six-hour fire ratings have been obtained.

The surface burning characteristics of Durisol far surpass all other types of stay-in-place formwork. Durisol has a flame spread and smoke spread rating of zero. Unlike foam, Durisol will not ignite, melt, sustain fire or release toxic fumes in the event of a fire.

- Over 4 hour Fire Resistance Rating
- Zero Flame Spread
- Zero Smoke Developed
- Zero Fuel Contributed

1.3.7 MOISTURE PROTECTION

Since no exterior finish will act as a perfect rain barrier, it is good practice to have a wall system that is capable of compensating for imperfections in the veneer. In the event that moisture does become temporarily trapped within the wall, the Durisol is capable of accommodating this moisture without any damage to itself. Damage to other wall components is of course a possibility. Although the Durisol material will not prevent moisture damage, it will mitigate the effects of moisture penetration through the exterior weather barrier. The behavior of Durisol in this regard is similar to any other type of cement based product with moisture storage capability - such as concrete masonry. The permeable nature of the Durisol serves to regulate the water vapour in the air and provides a smoothing effect to rapid swings in relative humidity.

1.3.8 TERMITE RESISTANCE

Unlike foam insulation, Durisol provides effective resistance to termite attack. A number of testing programs have been conducted where Durisol samples were placed in termite infested areas for as long as six years without any destruction of Durisol material occurring.

Table 1.4 – Termite Resistance of Durisol

Test Sample	Panel Damage Index (PDI)			
	3 years	4 years	5 years	6 years
Durisol placed on surface at termite test site	0.4	0.8	1.0	1.0
Durisol placed 2" below-grade at termite test site	0.4	0.6	1.0	1.0
Durisol set on wood base placed on surface of test site	0.6	0.6	1.0	1.0
Durisol placed 2" below-grade on wood base at test site	0.8	0.6	1.0	1.0
Durisol set 3" above grade on masonry base at test site	0.2	0.6	0.6	1.0
Durisol stored inside (no exposure to termites)	0	0	0	0
Control wood samples	5	4	4.5	5

* Summary of test report FS-SRS-4502-4.204 conducted by US Forest Service at termite facilities in Mississippi and Arizona. Contact Durisol for detailed test information.

- PDI:**
- 0.0 - Sound; no feeding or surface investigation
 - 1.0 - Surface investigation only
 - 2.0 - Light Damage; penetration into panel
 - 3.0 - Moderate Damage; penetration into panel
 - 4.0 - Heavy Damage; extensive penetration and damage to panel
 - 5.0 - Failure; complete or near complete destruction of panel

1.4 Construction Advantages

Durisol Wall Forms are lightweight and straightforward to use. With each Wall Form unit covering approximately 3 ft² (0.028m²) of wall area, construction is fast and efficient. This results in lower labour costs and shorter construction time.

The Durisol material can be easily cut, nailed and screwed with simple carpenter tools. This provides the builder with the flexibility to cut and fit shapes to suit site-specific situations. Wood bucks and bracing can be directly attached to the Durisol Wall Forms using nails and screws.

The insulating properties of Durisol Wall Forms allow winter construction without additional heating or insulation sources being required. Durisol wall systems have been constructed in temperatures as low as 22 °F (- 6°C) without any complication.

The unique free-draining Durisol material allows the use of high-slump concrete in the field that makes for easier and faster concrete pouring that ensures a solid wall without any compromise in strength. Ideally, concrete with a slump between 7” and 9” is recommended for use in conjunction with Durisol.

Interior and exterior finishes are applied directly to the Durisol material, eliminating subsequent steps in the construction process. Drywall can be attached *anywhere* on the Wall form surface, while the open-textured nature of hardened Durisol makes it an ideal substrate for plasters and stucco.

1.5 Design Flexibility

Durisol Wall Forms can be ordered with R-values ranging from R-8 to R-28+. This allows for optimal wall design catered to the specific applications (i.e. above-grade, below-grade, residential, commercial, etc). Designs can be customized to suit the needs of the project and provide the most cost-effective solution without compromising performance of the building envelope.

1.6 Research and Testing

Durisol is committed to research and development, with over 50 years of independent research, in-house testing and continuous improvement. Specific test reports on topics such as thermal resistance, fire performance, termite resistance, etc., may be available upon request.

1.7 Standard Wall Forms (Imperial)

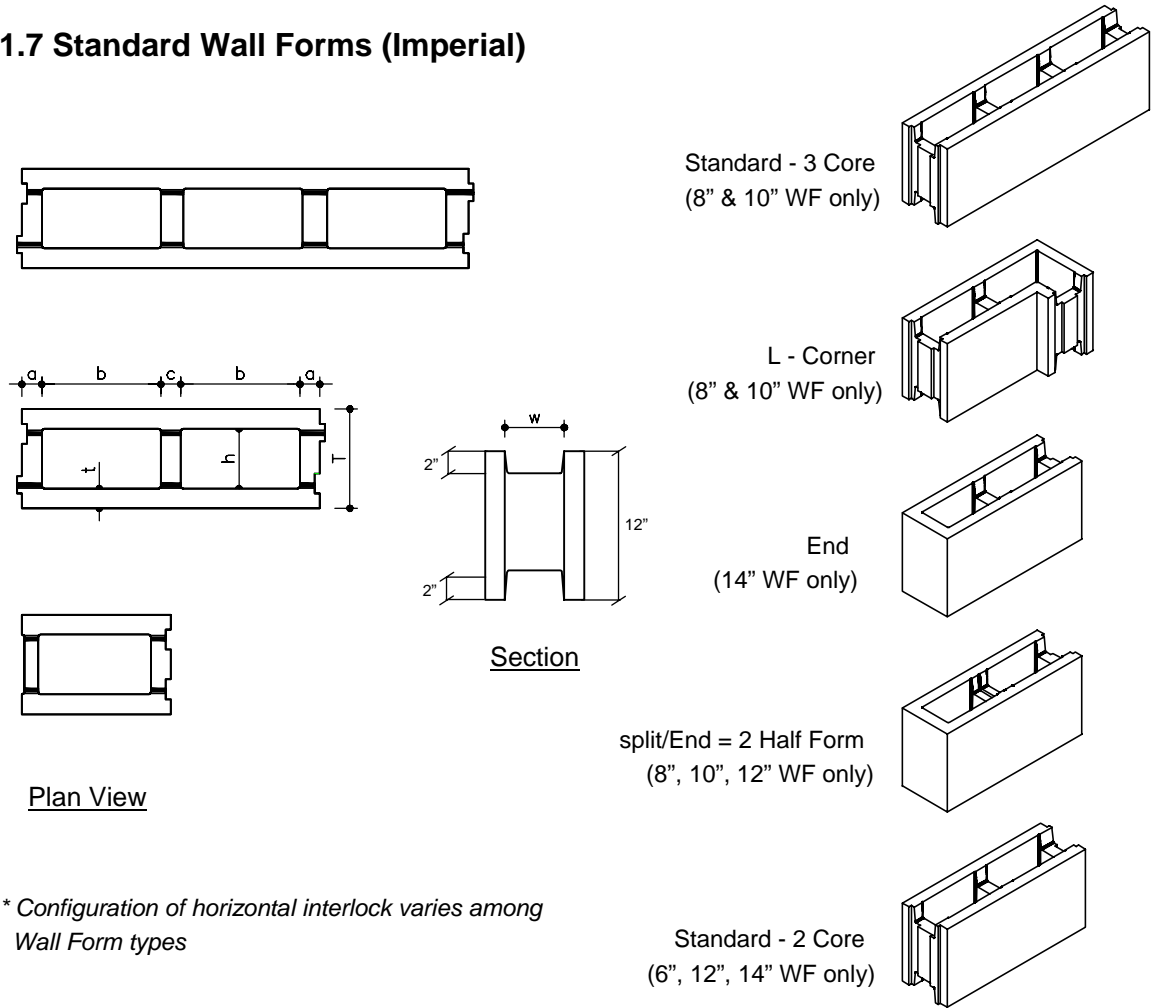

* Configuration of horizontal interlock varies among Wall Form types

Figure 1.2 – Standard Wall Form Schematic

Table 1.5 – Standard Wall Form Dimensions (Imperial)

Wall Form Type	Wall Form Weight (lbs)	FORM DIMENSIONS							CONCRETE CORE DATA	
		T (in)	t (in)	a (in)	c (in)	w (in)	b (in)	h (in)	X-Sect Area (in ²)	Fill Volume (yd ³ / ft ²)
6" WF	16	5 7/8	1 3/8	1 7/8	1 3/4	3 1/4	9 1/8	3 1/8	28.5	0.0078
8" WF	33	7 7/8	1 5/8	1 3/4	1 1/2	4 3/8	9 1/2	4 3/4	44.3	0.0123
10" WF	40	10	1 3/4	1 3/4	1 3/4	6 3/4	9 1/2	6 3/4	64.1	0.0179
12" WF	31	12	1 3/4	1 3/4	1 3/4	8 1/2	9 3/8	8 1/2	79.7	0.0217
14" WF	38	14	1 3/4	2	1 3/4	10 3/8	9 1/8	10 3/8	94.5	0.0265

1.8 Standard Wall Forms (SI)

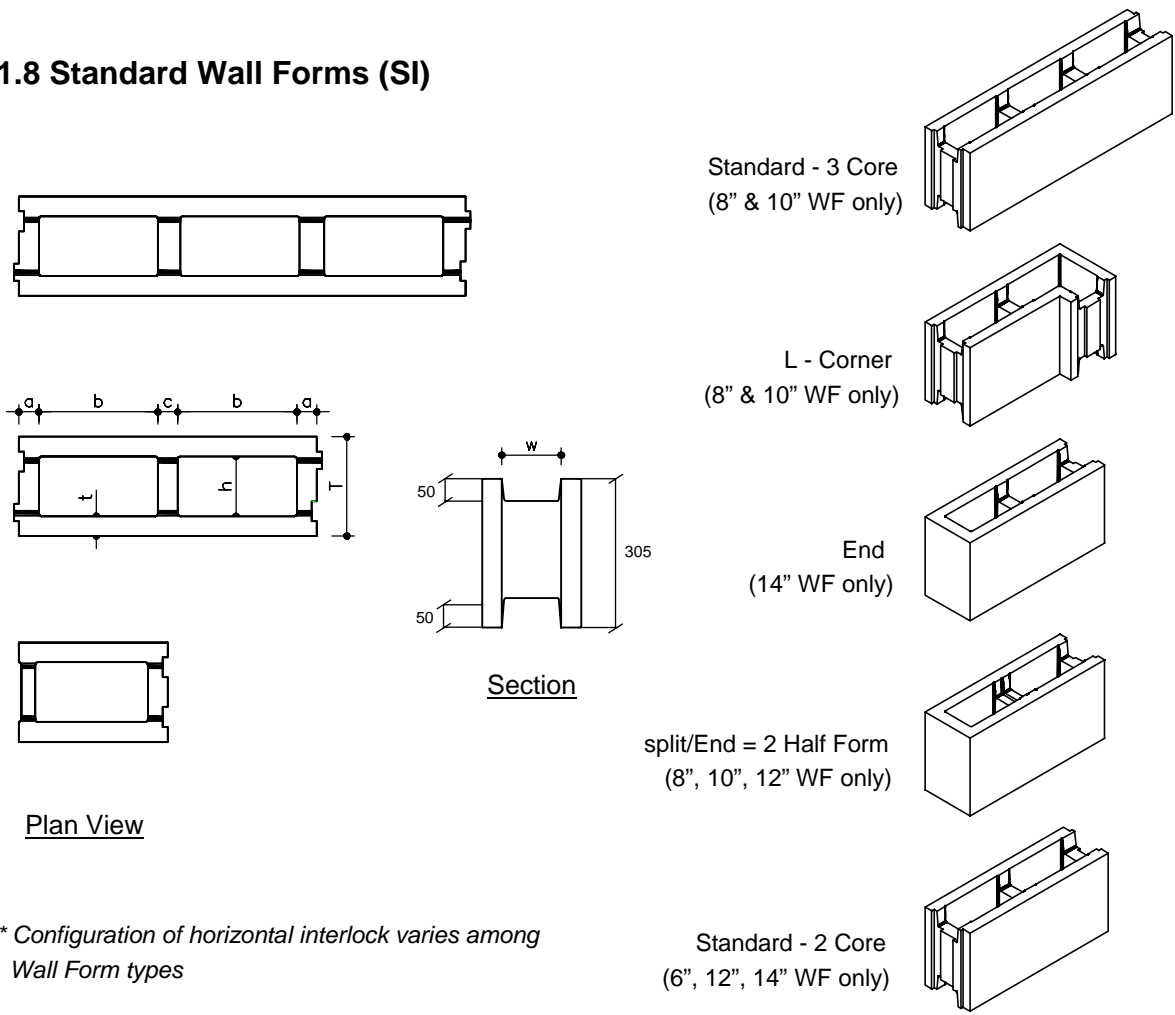

* Configuration of horizontal interlock varies among Wall Form types

Figure 1.3 – Standard Wall Form Schematic (SI)

Table 1.6 – Standard Wall Form Dimensions (SI)

Wall Form Type	Wall Form Weight (kg)	FORM DIMENSIONS							CONCRETE CORE DATA	
		T (mm)	t (mm)	a (mm)	c (mm)	w (mm)	b (mm)	h (mm)	X-Sect Area (mm ²)	Fill Volume (m ³ / m ²)
6" WF	8	150	35	46	46	80	233	80	18650	0.064
8" WF	15	200	40	43	38	120	238	120	28000	0.101
10" WF	18	255	42	45	45	172	242	172	41500	0.147
12" WF	14	305	45	45	45	216	238	216	51400	0.178
14" WF	17	360	45	51	48	265	232	265	61500	0.217

1.9 Thermal Wall Forms (Imperial)

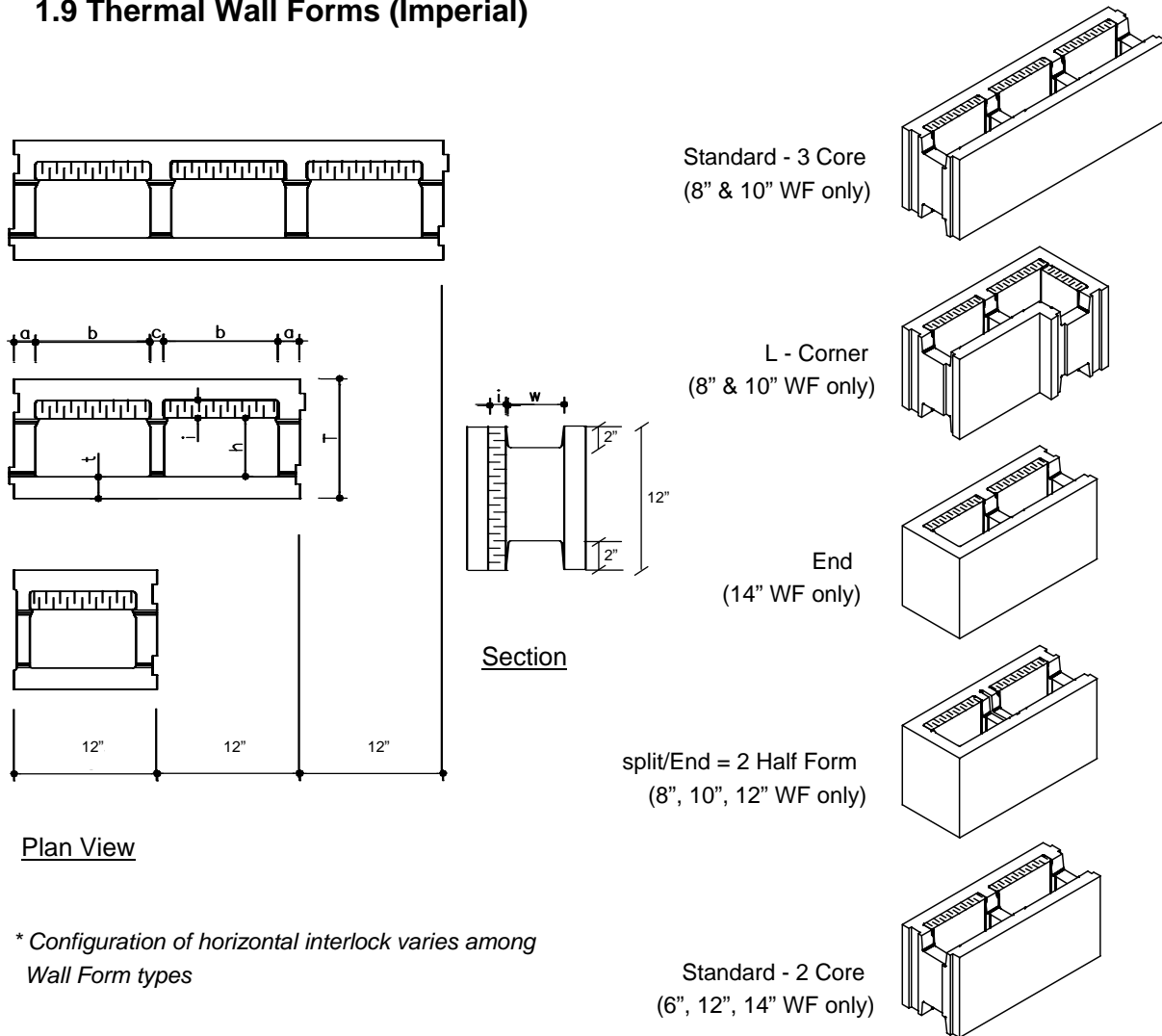

Plan View

* Configuration of horizontal interlock varies among Wall Form types

Figure 1.4 – Thermal Wall Form Schematic

Table 1.7 – Thermal Wall Form Dimensions (Imperial)

Wall Form Type	Wall Form Weight (lbs)	FORM DIMENSIONS								CONCRETE CORE DATA	
		T (in)	t (in)	a (in)	c (in)	w (in)	i (in)	b (in)	h (in)	X-Sect Area (in ²)	Fill Volume (yd ³ / ft ²)
10" WF (R-14)	43	10	1 3/4	1 3/4	1 3/4	5 1/4	1 1/2	9 1/2	5 1/4	49.9	0.0140
12" WF (R-14)	35	12	1 3/4	1 3/4	1 3/4	7	1 1/2	9 3/8	7	65.6	0.0186
12" WF (R-21)	39	12	1 3/4	1 3/4	1 3/4	5 1/2	3	9 3/8	5 1/2	52.3	0.0146
14" WF (R-14)	39	14	1 3/4	2	1 3/4	9	1 1/2	9 1/8	9	82.1	0.0225
14" WF (R-21)	41	14	1 3/4	2	1 3/4	7 1/2	3	9 1/8	7 1/2	68.4	0.0186
14" WF (R-28)	44	14	1 3/4	2	1 3/4	5 1/2	5	9 1/8	5 1/2	50.2	0.0140

1.10 Thermal Wall Forms (SI)

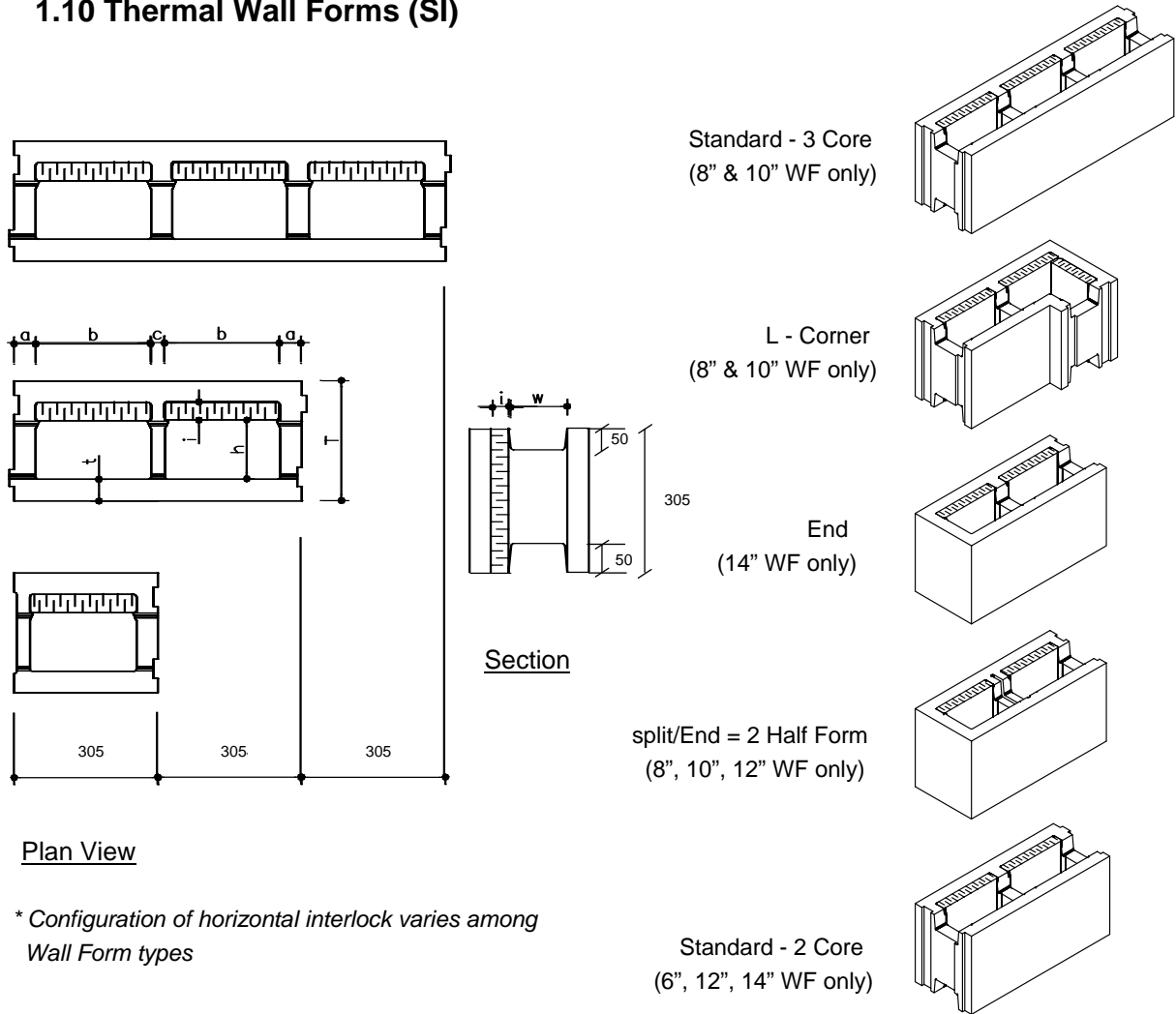

Plan View

* Configuration of horizontal interlock varies among Wall Form types

Figure 1.5 – Thermal Wall Form Schematic (SI)

Table 1.8 – Thermal Wall Form Dimensions (SI)

Wall Form Type	Wall Form Weight (kg)	FORM DIMENSIONS (mm)								CONCRETE CORE DATA	
		T	t	a	c	w	i	b	h	X-Sect Area (mm ²)	Fill Volume (m ³ / m ²)
10" WF (R-14)	20	254	45	45	45	133	38	241	133	32100	0.115
12" WF (R-14)	18	305	45	45	45	178	38	238	178	42300	0.153
12" WF (R-20)	19	305	45	45	45	140	76	238	140	33700	0.120
14" WF (R-14)	19	360	45	51	48	227	38	232	227	52650	0.185
14" WF (R-21)	20	360	45	51	48	190	76	232	190	44100	0.153
14" WF (R-28)	21	360	45	51	48	138	127	232	138	32100	0.115

1.11 Wall System Summary

The following Tables summarize the Wall Forms and overall wall systems that are possible using the standard Durisol Wall Forms.

Table 1.9 – Wall Form Types and Availability (Nominal Dimensions)

Wall Form Shape	Size (height x length)	AVAILABILITY				
		6" WF	8" WF	10" WF	12" WF	14" WF
Standard 3 Core	(12" x 36")	x	✓	✓	x	x
L - Corner (2 Core) ¹	(12" x 24")	x	✓	✓	x	x
Corner (Modified End)	(12" x 24")	✓	x	x	✓	✓
End (2 Core)	(12" x 24")	x	x	x	x	✓
Split/End (2 Core)	(12" x 24")	x	✓	✓	✓	x
Standard 2 Core	(12" x 24")	✓	x	x	✓	✓

¹ All Corner Wall Forms are L-shaped with 12" return. Since the WF30 system has a thickness of 12" , the corner unit is a modified End Unit.

Table 1.10 - Wall System Summary

Wall Thickness	R-Value	Concrete Thickness (in)	Concrete Fill Vol. (yd ³ / ft ²)	Total Weight of Wall (lb / ft ²)	Application
6"*	8	3 1/8	0.0078	27	Above Grade
8"	8	4 3/4	0.0123	35	Above Grade
10"	8	6 3/4	0.0179	46	Above & Below Grade
10"	14	5 1/4	0.0140	41	Above Grade
12"	8	8 1/2	0.0217	56	Above & Below Grade
12"	14	7	0.0186	50	Above & Below Grade
12"	21	5 1/2	0.0146	47	Above Grade
14"	8	10 3/8	0.0265	69	Above & Below Grade
14"	14	9	0.0225	62	Above & Below Grade
14"	21	7 1/2	0.0186	55	Above & Below Grade
14"	28	5 1/2	0.0140	46	Above Grade

* 6" WF is not typically intended for use as a load-bearing wall.

2.0 INSTALLATION

2.1 Modular Planning and Design

The Durisol Wall Form units are approximately 12" high x 36" long and come in various widths. Although it is not a requirement, planning the building layout on a 12" (305mm) horizontal module and 12" (305mm) vertical module will increase speed of construction. Also, having openings that are sized and placed on this 12" module will further increase the productivity of construction. Depending on how tightly the Wall Forms are stacked next to each other, a wall length can increase by as much as 1.5% during construction. For example 10 Wall Forms laid side by side can measure as much as 365" if not tightly placed next to each other. If the Wall Forms do require cutting, it is easily accomplished with a hand, circular, reciprocating saw or even chainsaw. Where cutting has destroyed the inherent stability of a Wall Form, pieces can be screwed together temporarily using ordinary wood screws.

2.2 Footings and Slabs-on-Grade

When considering the footings of a building, there is no differentiation between Durisol walls and concrete walls that are constructed using conventional forming techniques. The Durisol Wall Form system results in reinforced concrete walls that are 5.25", 7", 8.5" or 10.4" (125, 165, 220, 265mm) in thickness. Footings should be designed and constructed as following normal good practice, and in strict compliance with local building codes and regulations.

As with any type of construction, it is good practice to ensure that all footings are level. In the event that site conditions require step footings, it is recommended that vertical steps of 12" be used to correspond with the height of the Durisol Wall Form units. This will eliminate unnecessary on-site cutting of Wall Forms as courses can simply carry on past the footing over the course below. It is recommended that a key-way in the top of the footings be provided as well as steel reinforcing dowels that protrude from the top of the footing into the foundation wall. Although this is not required by most building codes, it is considered good building practice.

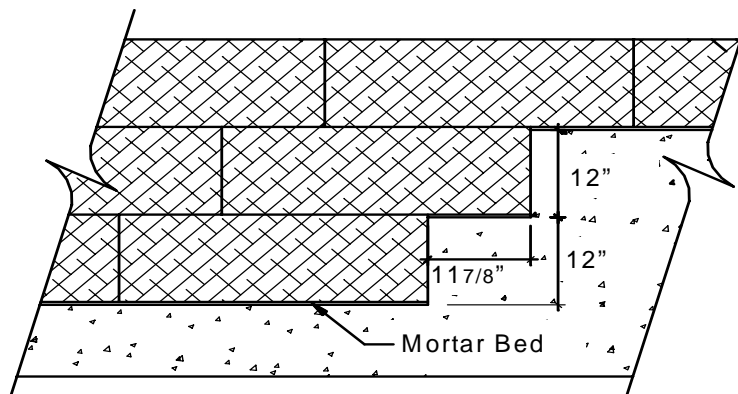

Figure 2.1 – Typical Step Footing

2.3 Wall Layout

Once the footings are in place, it is necessary to check the exact building dimensions (if not surveyed) and ensure that all corners are square. Once the corners have been pinned according to the specified building measurements, the footing should be marked with a chalk line to represent the inside and outside edges of the Wall Form. It is good practice to fasten guide boards to the footing along marked chalk lines. This will prevent complications from inadvertent removal of the chalk line or wall movement. When laying out chalk lines on the inside face of a wall, it is suggested that lines be marked approximately ½" (12mm) off the actual layout. This offset will allow lines to remain visible if subsequent adjustment is required during the first course placement.

Once the building is accurately laid out on the footing, mark locations of door and window openings for future reference.

2.4 Material Unloading and Placement

The Wall Forms are shipped on either conventional 48" x 48" pallets, stacked 7 courses (7 ft) high or 36" x 72" pallets stacked 6 high. Typically, the Durisol Wall Forms are shipped within a standard van-style trailer. Each pallet will weigh between 1400 and 2700 lbs (depending on Wall Form type), and a forklift will be required onsite for unloading of material. Forklifts are readily available at local construction equipment rental outlets at nominal cost.

Stacking the Wall Forms is easier from the inside of the structure. For this reason, all material should be placed inside the perimeter of the wall. Ideally, Wall Form pallets should be placed at a 10-foot spacing along the length of the walls with approximately 7 feet of space between the pallet and footing. This will eliminate unnecessary movement of Wall Form units around the job site. When moving Wall Forms, use caution and avoid reckless handling. The rough texture of the Durisol material makes it difficult to notice a damaged wall form.

2.5 Placement of First Course

Prior to placing the first course of Durisol Wall Forms, one should have the necessary material on hand for framing the rough window and door openings; using 2x8, 2x10 or 2x12 lumber, depending on the Wall Form thickness.

Because footings and slabs are never 100% level, the first course should be set in a 1/2" to 1" mortar bed that will allow for accurate leveling of the first course. *Accuracy at this stage assures that all subsequent courses are parallel, level and trouble free.* Other materials such as construction adhesive may be used in lieu of conventional mortar. Adjusting the embedment of the Wall Forms in the mortar bed will compensate for most uneven footings. Another method for correcting uneven footings is to use shims to level successive courses. Finally, if the footing is drastically uneven, the bottom of the Wall Forms can be cut to fit the contour of the footing.

Beginning at the corners, place a corner Wall Form so that it lines up with the building lines established earlier. The use of vertical guide boards at the corners can help in positioning the first and subsequent courses so that they do not move.

When using Wall Forms with insulation inserts, ensure that the insulation is placed on the outside face of the wall (typical for temperate climates). By first placing the corner forms and stringing a plumb line between them, stacking the remaining forms is made easy and accurate.

2.6 Placement of Subsequent Courses

The second course can be stacked immediately after placement of the first course and horizontal reinforcement. Beginning with the corner, stagger the corner block so that the “running bond” pattern is created in the wall. The running bond pattern is not essential to the integrity of the wall system and is primarily employed to increase wall stability during construction. While creating the running bond pattern, it is essential to ensure that the vertical cores of the wall forms are aligned from one course to the next.

Proceeding around the wall in the same direction as in the first course, a cutting pattern will be established that may be followed throughout the entire wall construction process. Following this method will group all cut forms in the same general location, thus ensuring easier installation of Wall Forms. Also, since all cut forms should be braced separately, grouping cut forms will minimize the extent of additional wall bracing required.

Check to ensure the wall is level when the first two courses of forms have been placed. Courses above the first and second can be placed by following the pattern established in the first two courses.

As stacking progresses, it will be necessary to accommodate the variances among Wall Form units by using shims, screws or other methods of adjustment (mortar, adhesive, etc.) to create a level and plumb wall prior to pouring.

2.7 Reinforcement

The requirements for using reinforcing steel in Durisol walls are as per conventional reinforced concrete construction. The engineer’s structural drawings will provide the relevant information regarding bar size and spacing, splice lengths, clear cover from edge of poured concrete, etc.

2.7.1 HORIZONTAL REINFORCING

The engineering requirements will determine the size and position of the horizontal reinforcing. These requirements should be noted on the building drawings or engineers shop drawings. Horizontal reinforcing should be installed prior to the placement of the next course.

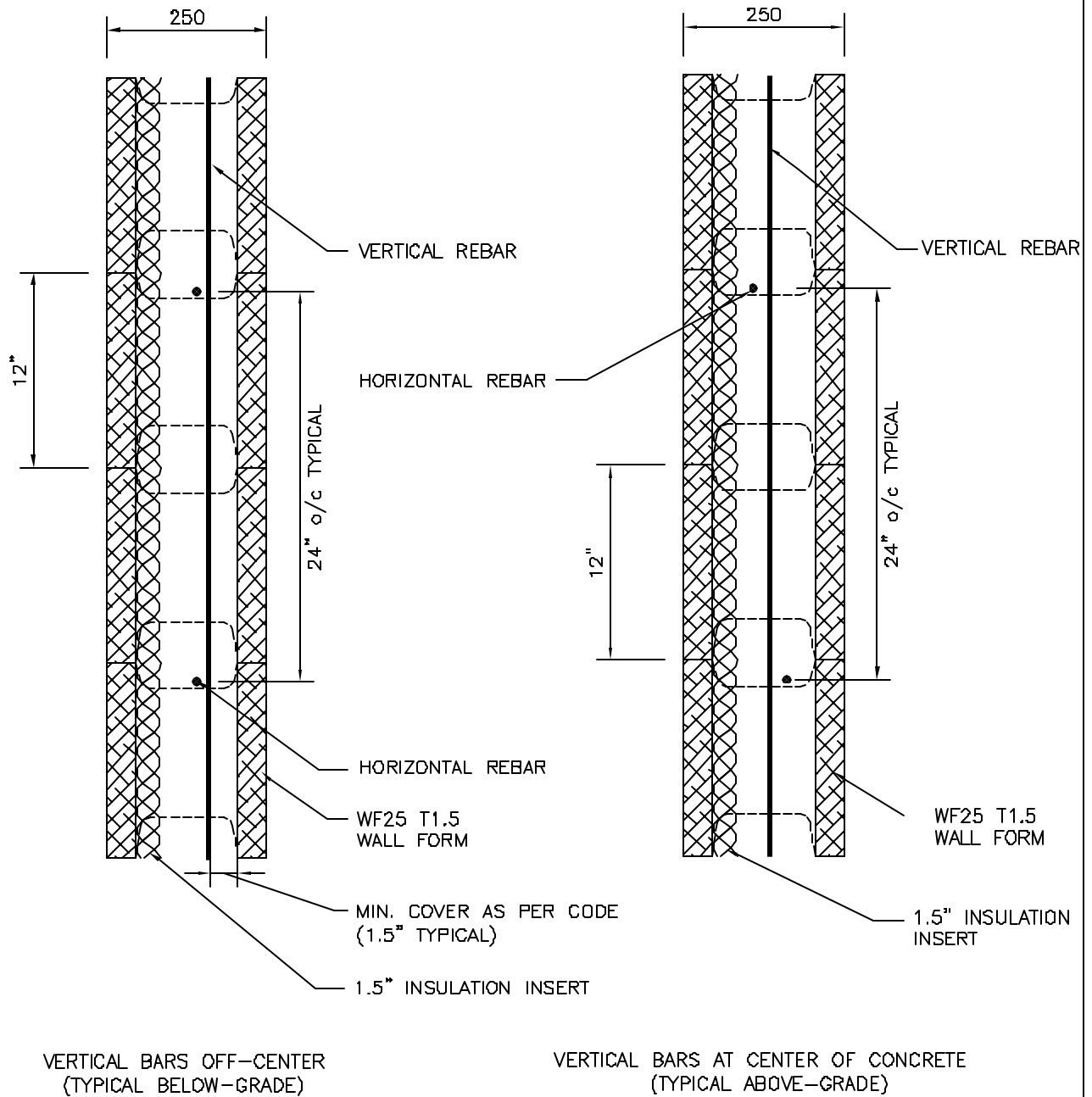

TITLE:
 REINFORCEMENT PLACEMENT

PROJECT:
 TECHNICAL GUIDE

DATE: 08.11.99	REVISED:	DRAWN BY: BTBH	CHECKED BY: VA	FILE NAME: DTG-1
-------------------	----------	-------------------	-------------------	---------------------

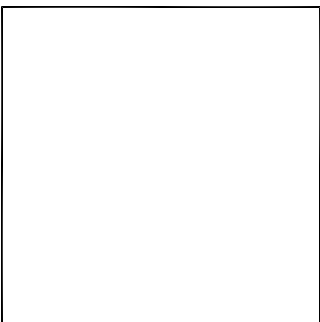

FIGURE:
 2.2

SCALE:
 1 : 10

DWG. NO:
 DTG-1

The Durisol Wall Forms have small grooves in the web that allow placement of the horizontal rebar towards either the inside or outside of the wall. In below grade construction, the horizontal rebar can ensure the positioning of the vertical steel towards the inside face of the Wall Form while still maintaining the minimum required clear cover. In the case of above grade construction, the builder should stagger the horizontal rebar between the inside and outside groove. This allows the builder to easily slide the vertical reinforcing down from the top of the wall, so that the steel fits between the horizontal reinforcing (i.e. in the center of the wall).

It is recommended to secure the horizontal rebar into position with a nail or clip every 6 feet. All reinforcing steel should be continuous, that is, lapped in accordance with applicable codes (typical minimum lap length is 40 x bar diameter) and bent around corners. It is not necessary to tie or fasten the reinforcing bars.

2.7.2 VERTICAL REINFORCING

Placing the vertical reinforcement so that it is positioned between the staggered horizontal rebar will ensure that the vertical reinforcing is held away from the face of the form, and guarantees that the required concrete cover will be maintained.

Vertical reinforcement is inserted prior to, or immediately after the concrete has been placed. It should be continuous or lapped where required. Lapping of rebar should be avoided at the mid-height of the wall and should be accommodated elsewhere along the height. Typically, the rebar will extend past the top of the pour sequence to accommodate the required lap lengths. All reinforcement requirements including minimum lap length should be based on the applicable concrete standards and building codes. The contractor should use a pouring sequence that ensures all bars meet the required minimum lap distances.

Because of the relatively secured positioning of the reinforcement, tied reinforcement is not typically required.

2.8 Door and Window Openings

Doors and window frames, whether wrap around or butt-type are easily installed while stacking Wall Forms. Openings in the Durisol wall system should be sized to accommodate the rough stud opening (RSO or RO) **plus** the thickness of the window buck. Also include any allowances necessary for exterior finishes. If Durisol End units are employed instead of wood bucks on the vertical sides of the opening, the horizontal opening length is not increased beyond the size of the RSO. Frames should have the same dimensions as the RSO dimensions supplied by the window or door manufacturer. Installing the frames during construction of the walls avoids the necessity for temporary opening bucks or Durisol End Units along the vertical sides and under the lintel. It also allows the fill concrete to flow directly against the frames to allow proper seal between the frames and the wall.

It is the designer's responsibility to ensure that all flashing and moisture protection around openings are adequately detailed to prevent moisture penetration.

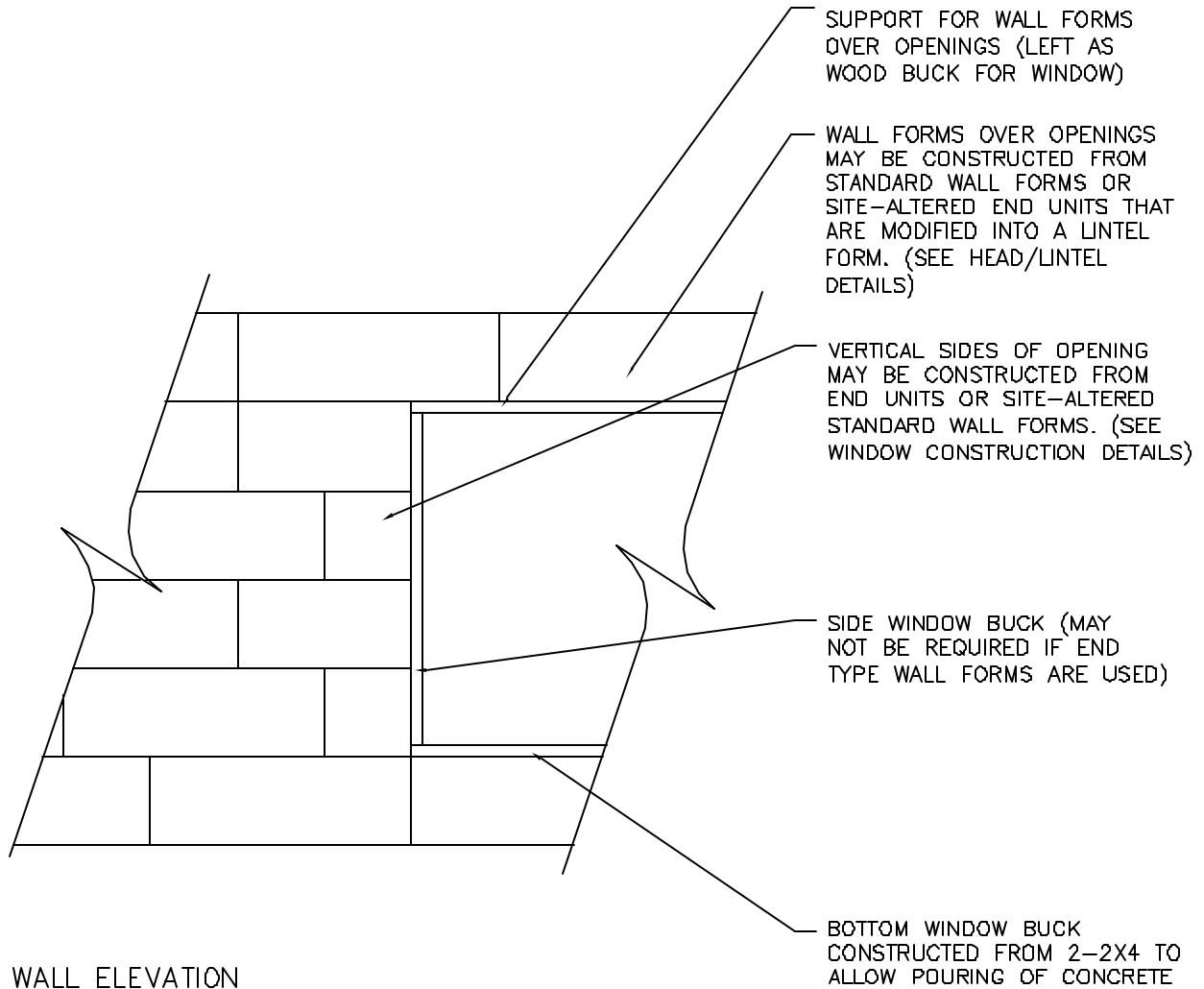

WALL ELEVATION

NOTES:

1. WINDOW BUCKS SHOULD BE SECURED THROUGH THE DURISOL INTO CAVITY BEFORE POURING CONCRETE.
2. SITE-ALTERED WALL FORMS WILL REQUIRE ADDITIONAL BRACING TO PREVENT SPLITTING OF FORMS AND ENSURING PLUMB AND SQUARENESS OF OPENING.
3. WINDOW BUCK WILL REQUIRE TEMPORARY SUPPORT (VERTICAL STRUTS) UNTIL CONCRETE HAS CURED.
4. ABOVE DIAGRAM APPLIES TO DOOR OPENINGS IN ADDITION TO WINDOW OPENINGS.

TITLE:
 WINDOW OPENING AND BUCK DETAIL-1

PROJECT:
 TECHNICAL GUIDE

DATE: 08.11.99	REVISED:	DRAWN BY: BTBH	CHECKED BY: VA	FILE NAME: DTG-2
-------------------	----------	-------------------	-------------------	---------------------

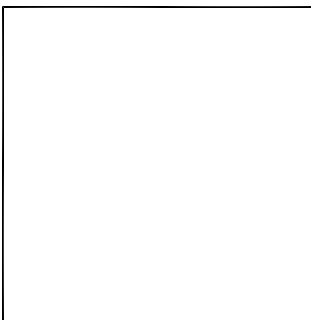
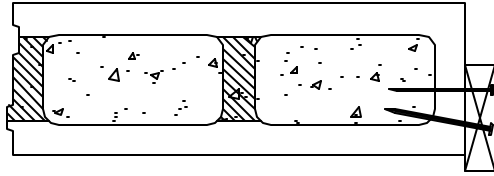

FIGURE:
 2.3

SCALE:
 1 : 25

DWG. NO:
 DTG-2

INTERIOR



OPTION 1

USE END WALL FORM WITH BUCK POSITIONED TOWARD EXTERIOR AND LIP PROVIDED FOR EXTERIOR FINISH TRANSITION AND MOULDING.

INTERIOR

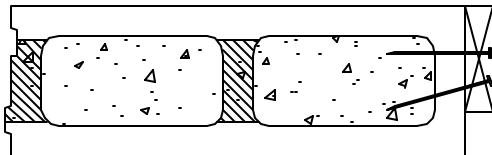

OPTION 2

USE END WALL FORM WITH BUCK POSITIONED TOWARD INTERIOR TO ALLOW RETURN OF EXTERIOR FINISH AROUND OPENING

INTERIOR

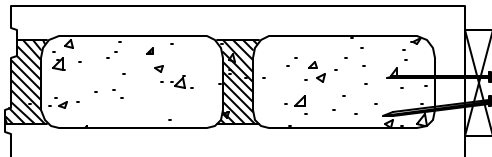

OPTION 3

USE END WALL FORM WITH BUCK POSITIONED TOWARD CENTER OF WALL TO ALLOW RETURN OF BOTH INTERIOR AND EXTERIOR FINISH AROUND OPENING

INTERIOR

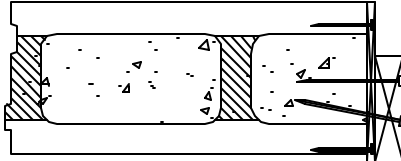

OPTION 4

USE SITE-ALTERED STANDARD WALL FORM WITH BUCK POSITIONED TOWARD EXTERIOR AND LIP PROVIDED FOR EXTERIOR FINISH TRANSITION AND MOULDING

INTERIOR

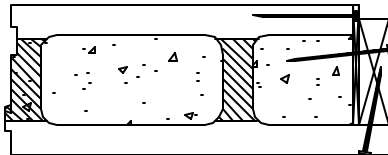

OPTION 5

USE SITE-ALTERED STANDARD WALL FORM WITH BUCK POSITIONED BEHIND DURISOL

NOTE:

1. MAY ALSO INSTALL WINDOW FRAME DIRECTLY AGAINST DURISOL END WALL FORM WITHOUT WOOD BUCK
2. OTHER CONFIGURATIONS FOR WINDOW JAMBS ARE POSSIBLE. CONTACT DURISOL FOR MORE INFORMATION.

TITLE:
WINDOW BUCK DETAIL AT JAMB (STD)

PROJECT: TECHNICAL GUIDE

DATE:
08.11.99

REVISED:

DRAWN BY:
BTBH

CHECKED BY:
VA

FILE NAME:
DTG-3

FIGURE:
2.4

SCALE:
1 : 10

DWG. NO:
DTG-3

INTERIOR

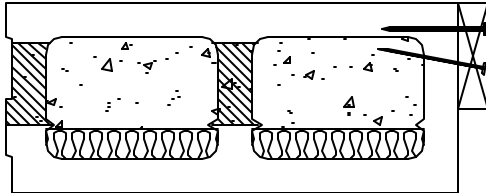

OPTION 1

USE END WALL FORM WITH BUCK POSITIONED TOWARD INTERIOR TO ALLOW RETURN OF EXTERIOR FINISH AROUND OPENING

INTERIOR

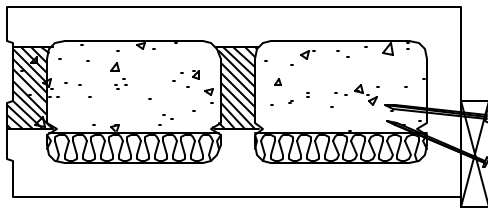

OPTION 2

USE END WALL FORM WITH BUCK POSITIONED TOWARD EXTERIOR AND LIP PROVIDED FOR EXTERIOR FINISH TRANSITION AND MOULDING

INTERIOR

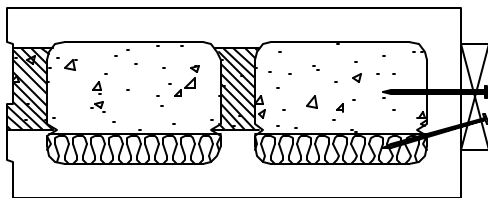

OPTION 3

USE END WALL FORM WITH BUCK POSITIONED TOWARD CENTER OF WALL TO ALLOW RETURN OF BOTH INTERIOR AND EXTERIOR FINISH AROUND OPENING

INTERIOR

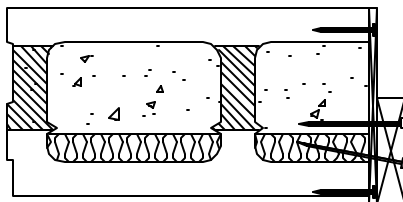

OPTION 4

USE SITE-ALTERED STANDARD WALL FORM WITH BUCK POSITIONED TOWARD EXTERIOR AND LIP PROVIDED FOR EXTERIOR FINISH TRANSITION

NOTE:

OTHER CONFIGURATIONS FOR WINDOW JAMBS ARE POSSIBLE. CONTACT DURISOL FOR ADDITIONAL INFORMATION.

TITLE:
WINDOW BUCK DETAIL AT JAMB (THERMAL)

PROJECT:
TECHNICAL GUIDE

DATE: 08.11.99	REVISED:	DRAWN BY: BTBH	CHECKED BY: VA	FILE NAME: DTG-4
-------------------	----------	-------------------	-------------------	---------------------

FIGURE:
2.5

SCALE:
1 : 10

DWG. NO:
DTG-4

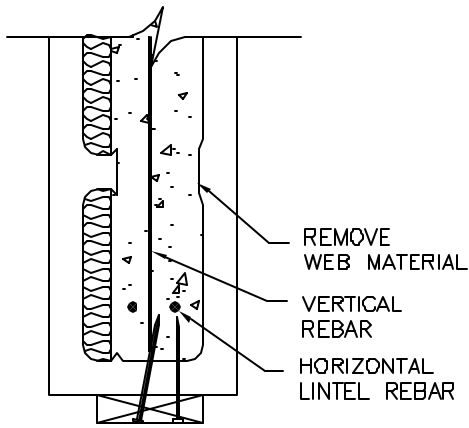

OPTION 1

USE SITE-ALTERED END WALL FORM WITH BUCK POSITIONED AS REQUIRED FOR WINDOW LOCATION. INTERIOR WEBS OF WALL FORM ARE REMOVED TO ALLOW SOLID CONCRETE LINTEL

LINTEL FORM (SITE-ALTERED END UNIT)

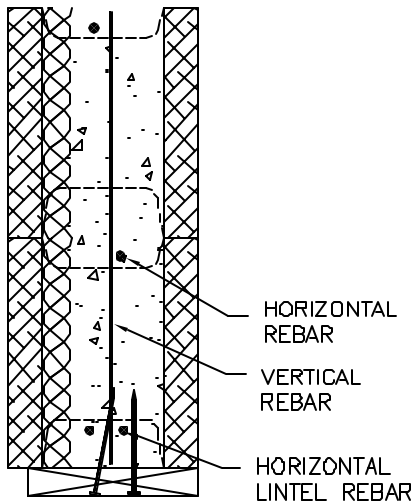

OPTION 2

USE STANDARD WALL FORM WITH BUCK POSITIONED AS REQUIRED FOR WINDOW LOCATION.

STANDARD COURSE LINTEL

NOTE:

1. TYPE OF DURISOL LINTEL (LINTEL FORM OR STANDARD COURSE) WILL DEPEND ON STRUCTURAL REQUIREMENTS AND ROOM AVAILABLE OVER OPENING.
2. NON-DURISOL LINTELS ARE FREQUENTLY USED BY INCORPORATING STRUCTURAL STEEL OR BUILT-UP LUMBER LINTEL INTO THE DURISOL WALL. THE EXTERIOR OF NON-DURISOL LINTELS ARE COVERED WITH DURISOL MATERIAL TO MAINTAIN CONTINUITY OF EXTERIOR SURFACE.

TITLE:
WINDOW BUCK DETAIL AT HEAD (DURISOL)

PROJECT: TECHNICAL GUIDE

DATE:
08.11.99

REVISED:

DRAWN BY:
BTBH

CHECKED BY:
VA

FILE NAME:
DTG-5

FIGURE:
2.6

SCALE:
1 : 10

DWG. NO:
DTG-5

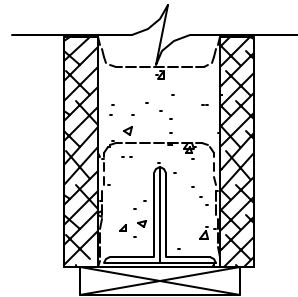
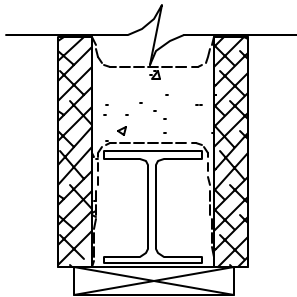

STEEL LINTEL

OPTION 1

USE CORRECTLY SIZED BEAM OR ANGLES TO FIT INSIDE WALL FORM OVER OPENING. WALL FORM WEBS WILL REQUIRE SITE ALTERATION TO ACCOMODATE LINTEL DEPTH.

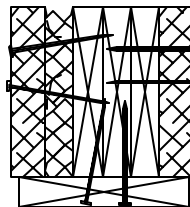

BUILT-UP WOOD LINTEL

OPTION 2

USE SITE-CUT WALL FORM FACE MATERIAL TO ENCLOSE CONVENTIONAL BUILT-UP LUMBER LINTEL.

NOTE:

1. TYPE OF DURISOL LINTEL (LINTEL FORM OR STANDARD COURSE) WILL DEPEND ON STRUCTURAL REQUIREMENTS AND ROOM AVAILABLE OVER OPENING.
2. NON-DURISOL LINTELS ARE FREQUENTLY USED BY INCORPORATING STRUCTURAL STEEL OR BUILT-UP LUMBER LINTEL INTO THE DURISOL WALL. THE EXTERIOR OF NON-DURISOL LINTELS ARE COVERED WITH DURISOL MATERIAL TO MAINTAIN CONTINUITY OF EXTERIOR SURFACE.

TITLE:
WINDOW BUCK DETAIL AT HEAD (OTHER)

PROJECT: TECHNICAL GUIDE

DATE: 08.11.99	REVISED:	DRAWN BY: BTBH	CHECKED BY: VA	FILE NAME: DTG-6
-------------------	----------	-------------------	-------------------	---------------------

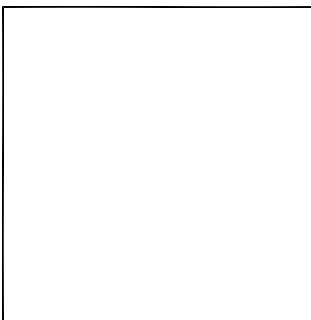

FIGURE:
2.7

SCALE:
1 : 10

DWG. NO:
DTG-6

It is recommended that the bottom of the window buck be created with two smaller pieces of wood (2x4 typically) in a manner that will provide a slot below the opening to allow proper placement and consolidation of concrete below the opening. Having the bucks pre-built can increase on-site productivity considerably. Once the forms are erected, openings may require bracing to prevent deflection of the wood frame under wet concrete pressure. This can be accomplished by placing a piece of lumber in the opening to brace from side to side and/or top to bottom.

2.9 Reinforcement at Door and Window Openings

The concrete lintel above the opening must be adequately reinforced to carry the required structural loads. Consult a local engineer for specific reinforcing information. Lintels for all Wall Forms can be designed in accordance with the Prescriptive Method of Insulating Concrete Forms, or the 1999 Standard Building Code, or the 2000 International Building Code.

The Durisol Design Guide will provide general reinforcing information that ***must be confirmed by a local design professional***. Design review is necessary to properly determine the reinforcement required to strengthen the lintel area to support the loads being imposed on it. Some factors to consider are:

- Opening width
- Depth of lintel (i.e. number of courses above the opening)
- Strength of concrete
- Width of concrete (depends of Wall Form type)
- Roof and floor loads that are applied to the lintel
- Concentrated point loads the occur over openings

Openings in concrete walls also require reinforcing around the perimeter to control cracks due to normal concrete shrinkage. This steel is required in all concrete walls, both plain and reinforced. Reinforcement requirements are outlined in ACI 318 or ACI 332, and CSA A23.3.

2.10 T-Walls and Pilasters

T-intersections and Pilasters can be formed easily with Durisol Wall Forms by simply cutting the forms to allow the perpendicular wall to intersect. Although not absolutely necessary, by alternating how the form units are cut when forming a tee intersection, it is possible to maintain an interlock between each wall. Reinforcing steel in the wall should be in accordance with structural drawings.

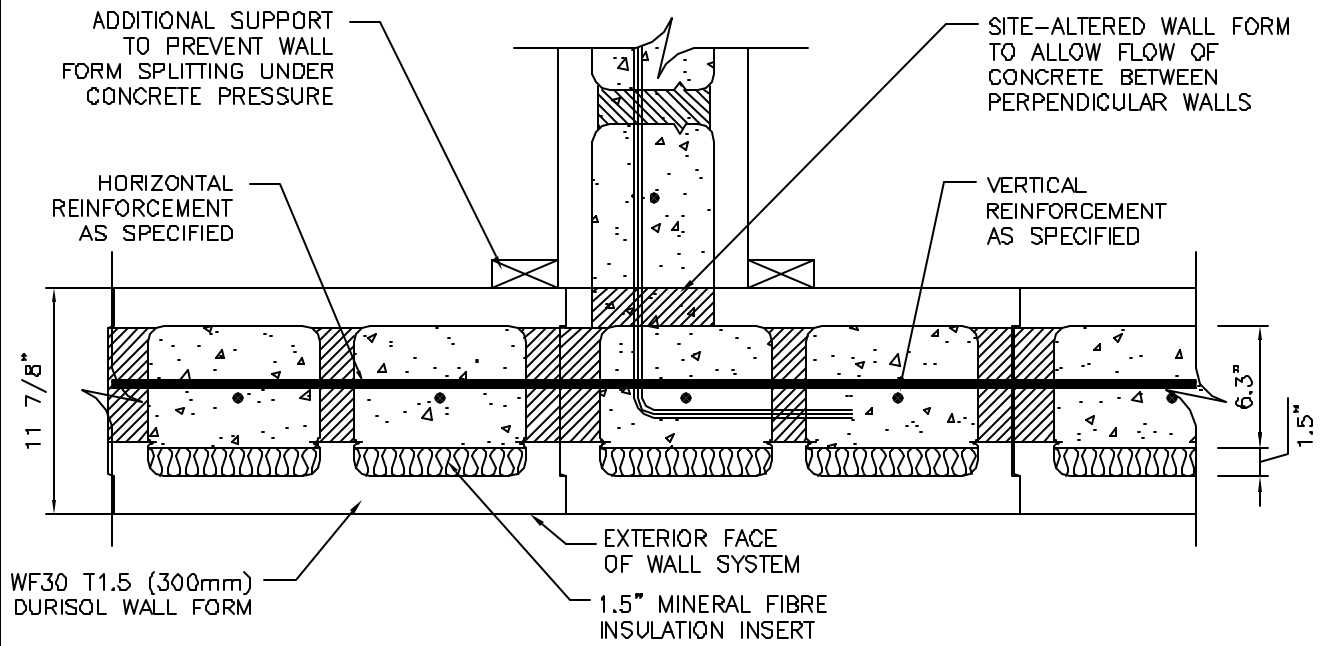

T-WALL CONFIGURATION (FIRST COURSE)

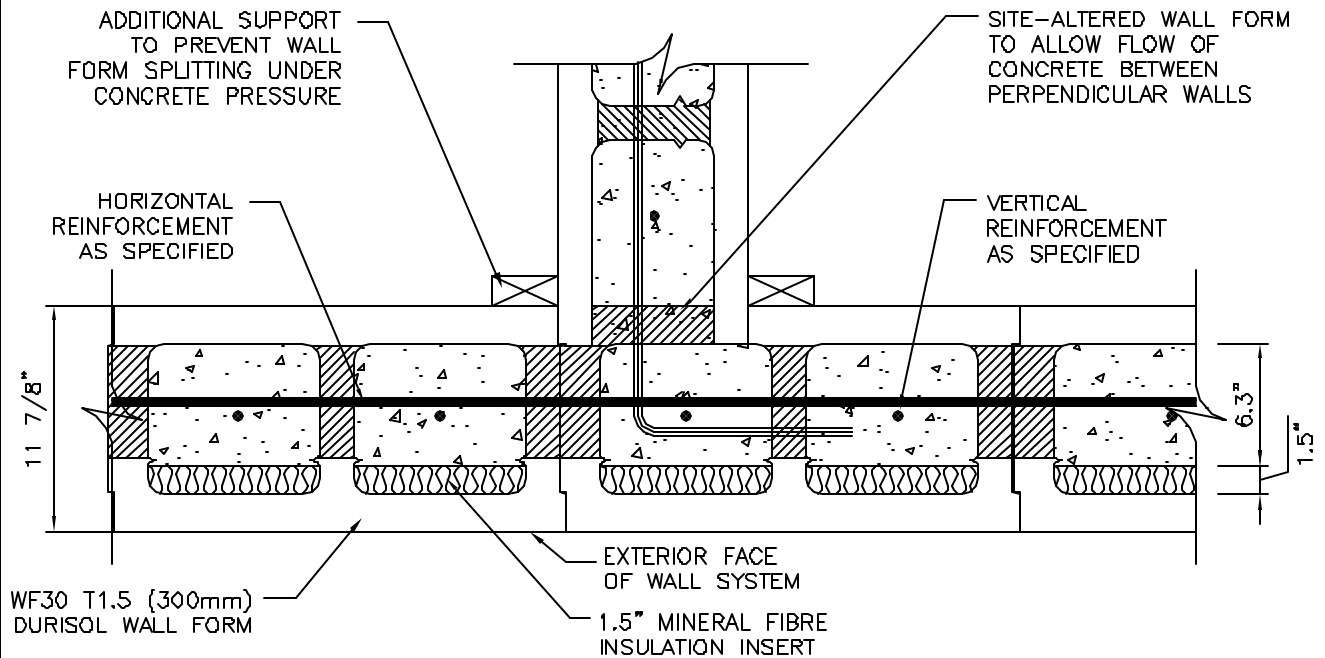

T-WALL CONFIGURATION (ALTERNATE COURSE)

TITLE: T-WALL CONSTRUCTION					FIGURE: 2.8	
PROJECT: TECHNICAL GUIDE						SCALE: 1 : 10
DATE: 08.11.99	REVISED:	DRAWN BY: BTBH	CHECKED BY: VA	FILE NAME: DTG-7		DWG. NO: DTG-7

2.11 Non 90° Corners

Corners that are not 90° can be accommodated by cutting Wall Forms on an angle equal to the desired corner angle. These modified Wall Forms should be fastened together with additional bracing. Since on-site alterations will reduce the inherent strength of the Wall Form, the additional bracing is required to guard against breakage during pouring. It may prove easier to use a stack-bond pattern in areas such as special corners, where Wall Forms require on-site alterations. This allows the installer to build a section of wall and alter (i.e. cut) the Wall Forms all at once along the height of the wall. Any type of saw (e.g. chain saw, reciprocating saw, etc.) may be used to cut the Wall Forms.

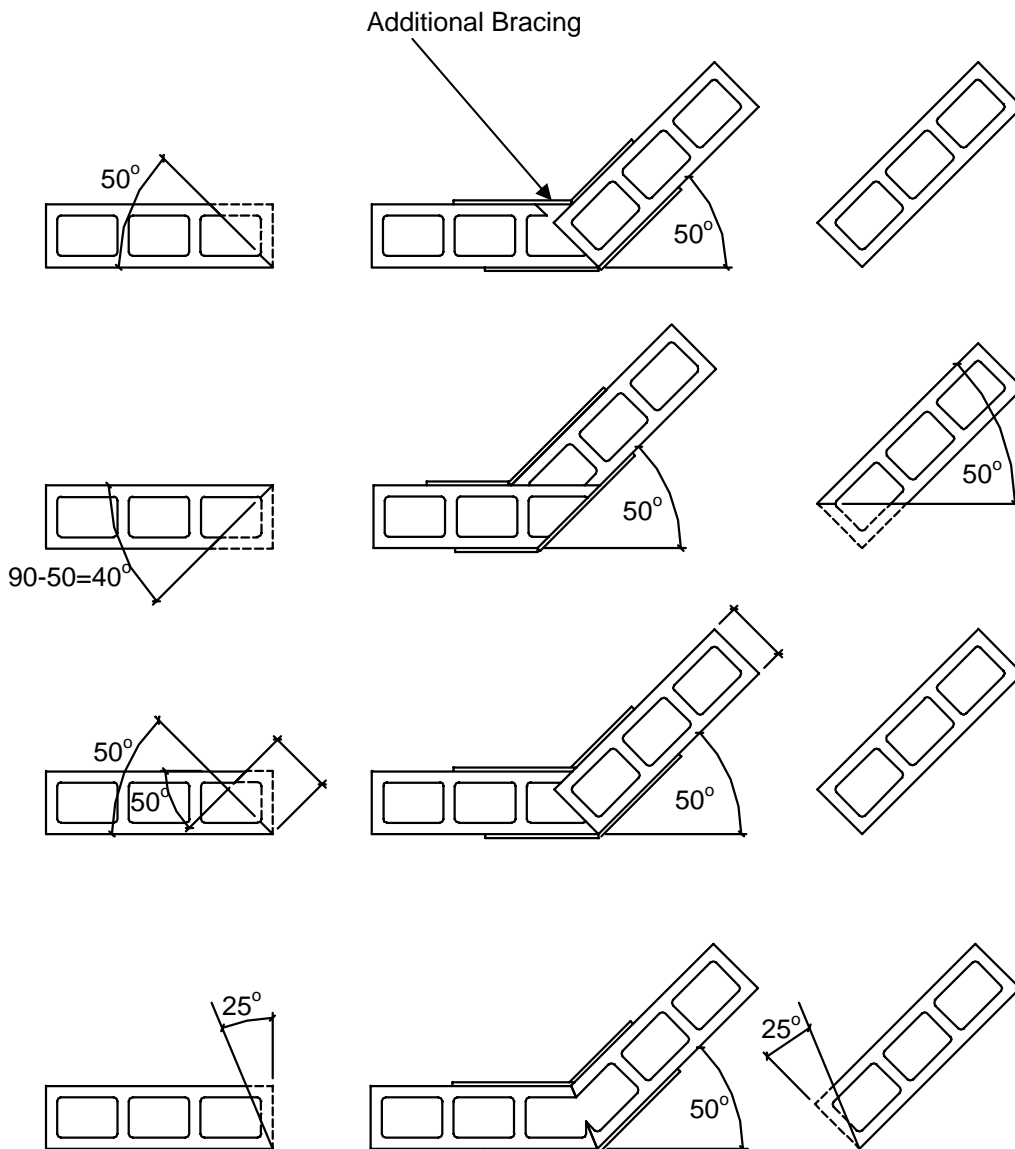

Figure 2.9 – Non-90° Corners

2.12 Wall Alignment and Bracing

There are numerous methods to ensure wall alignment. Experience has shown that depending on the individual preference of the installer any combination of the following alignment options may be employed.

Option 1 – No Integral Alignment

The Durisol Wall Forms weigh approximately the same as a conventional masonry unit (35-45 lbs) but cover over three times the wall surface area (i.e. each Wall Form covers up to 3 ft² of wall area). Because of the weight and inherent stability of the Wall Form, interconnecting the Wall Form units vertically from one course to the next is not always required. As long as concrete is poured in four foot lifts, and proper care is taken during the erection and pouring of the wall, it is possible to build the Durisol wall system without interlocking the Wall Forms vertically. Occasionally, Wall Forms may be nailed or screwed together as required. This has been the standard practice for Durisol construction for over 50 years.

Option 2 – Using the Durisol Alignment Wedges

Since 1998, the Durisol Wall Forms have been manufactured with an alignment groove on the top and bottom of one side of the Wall Form. The alignment wedges that are provided will naturally extend beyond the top of the Wall Form when inserted into the top groove of a Wall Form. When the next Wall Form is laid on top of the unit with the protruding wedge, the wedge becomes automatically inserted into the bottom groove of the Wall Form and connects all of the Wall Forms together. Wedges may be left out where required (ex. at corner units, cut areas, etc.).

Option 3 – Using other conventional alignment methods

Installers can also employ other methods of ensuring wall alignment including:

- Using conventional screws and nails to fix Wall Forms together and prevent relative movement
- Using conventional construction adhesive (durabond, liquid nailer, etc.) to fix Wall Forms together. Care should be taken with this method, as minor adjustments are difficult after the adhesive has set.

Once the wall has been erected and aligned, bracing will be required to keep the wall plumb and in position prior to and during the concrete pour. Any type of conventional bracing can be used including conventional lumber and/or proprietary wall bracing and alignment systems that are available for ICF products. Wall bracing is typically spaced at 8 ft but can be adjusted depending on quality of construction and other requirements (such as spacing of scaffold supports, etc.).

Additional bracing will also be required at sections such as wall lintels, cantilevers and other sections that have been weakened by cutouts. Once the fill concrete has hardened, the elements become self-supporting. Temporarily shoring the corners is good building practice and will provide string line connections. Once poured, the entire wall should be supported with standard construction braces until the roof or floor is installed and supporting the top of the wall. In the case of foundation walls, no backfilling should occur until the top of the floor is securely fastened to the floor assembly. The height and distance between wall braces should be in accordance with applicable standards.

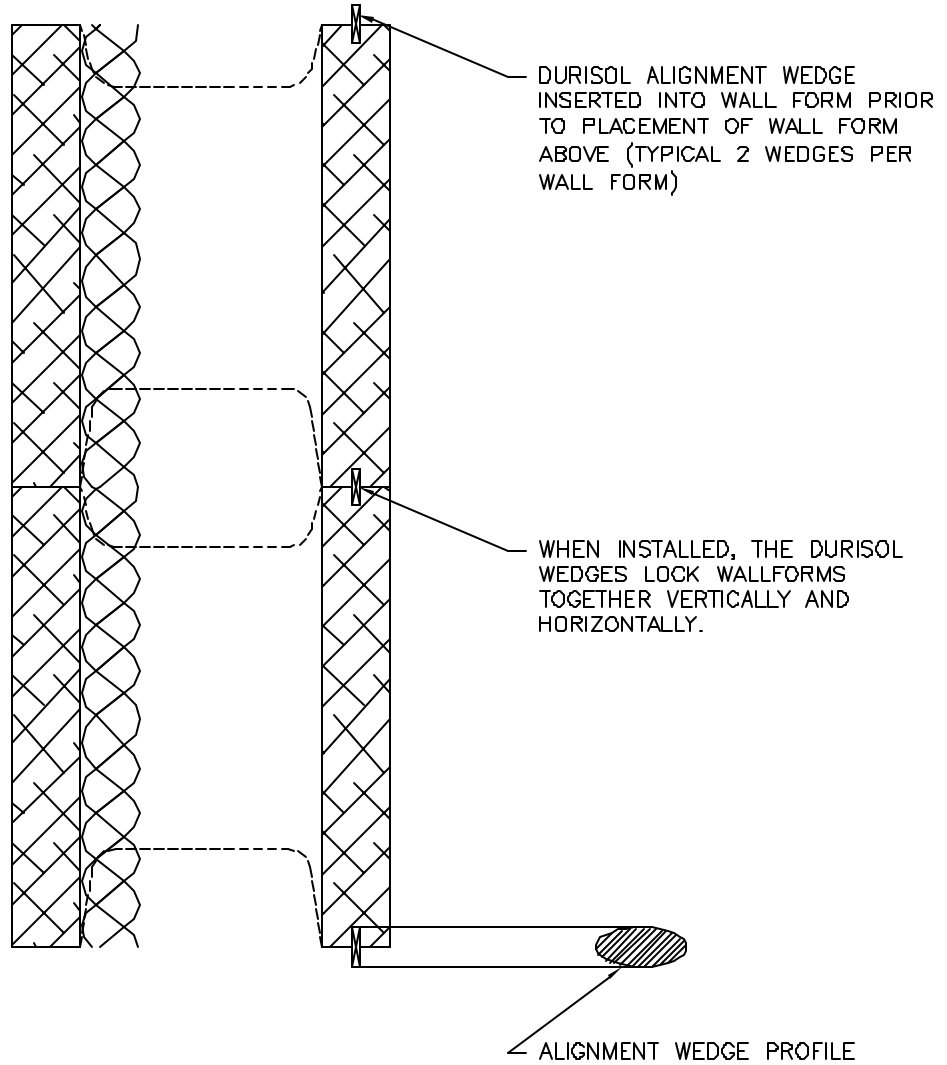

TITLE:
ALIGNMENT WEDGE INSTALLATION

PROJECT:
TECHNICAL GUIDE

DATE:
08.11.99

REVISED:

DRAWN BY:
BTBH

CHECKED BY:
VA

FILE NAME:
DTG-8

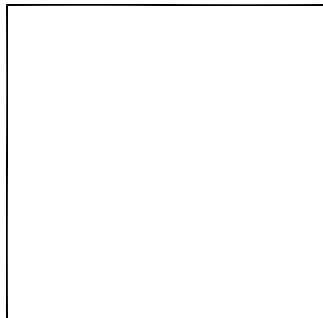
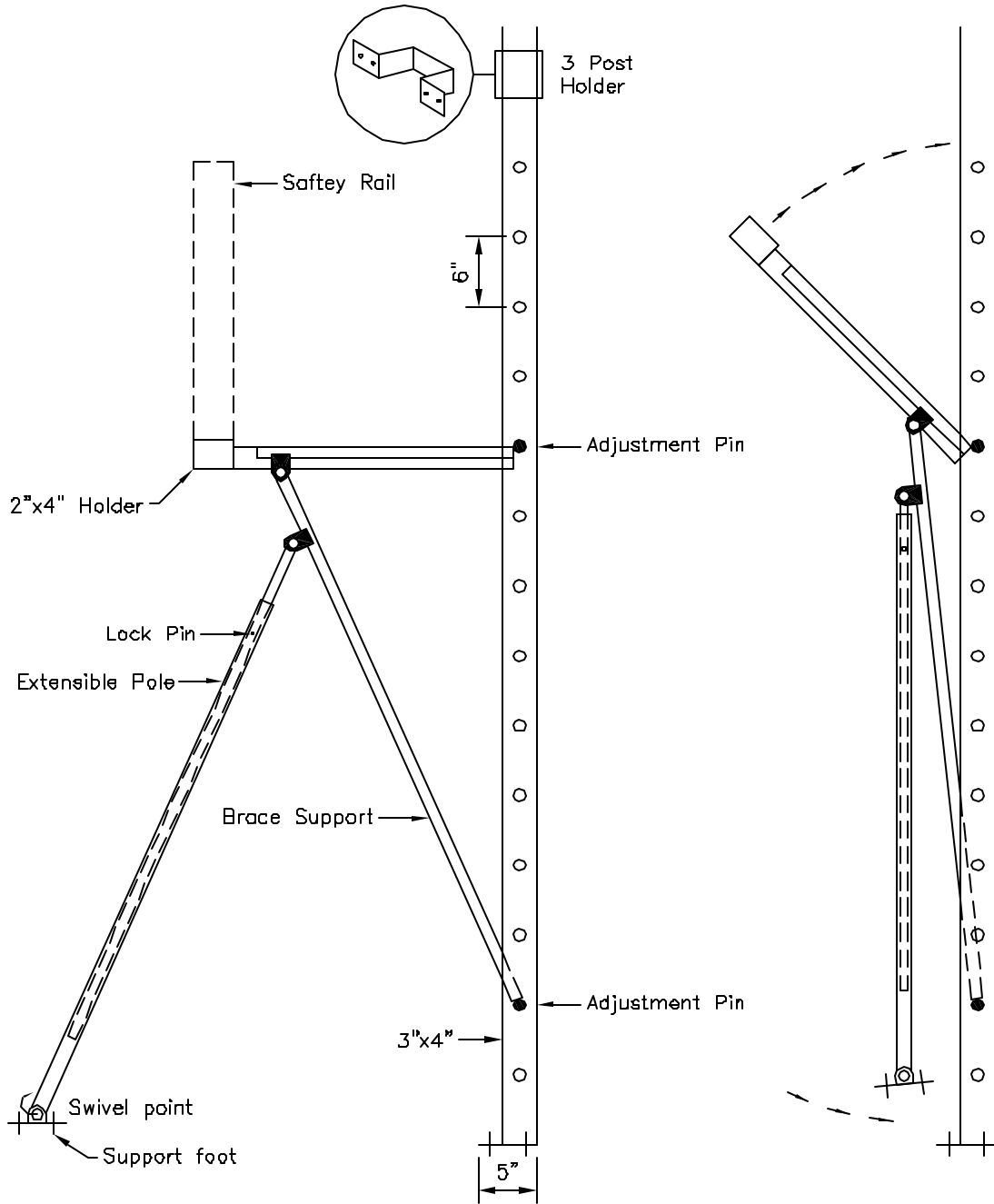

FIGURE:
2.10

SCALE:
1 : 10

DWG. NO:
DTG-8



TITLE: **COMBINED BRACING/SCAFFOLDING/ALIGNMENT SYSTEM**

PROJECT: **DURISOL BUILDING SYSTEMS INC.**

DATE: 05.16.03

REVISED:

DRAWN BY: AJK

CHECKED BY: VA

FILE NAME: DTG-8a

FIGURE:

SCALE: 1 : 10

DWG. NO: **DTG - 8a**

2.13 Electrical Services and Wall Penetrations

The Durisol Wall System easily accommodates electrical wiring and electrical service outlets. Surface grooves and outlet holes may be cut or drilled with ease using a router. The Wall Form surface material has sufficient depth to accommodate outlet boxes without the necessity to remove core concrete material. Alternately, electrical wires or conduits may be placed internally within the Wall Form cores prior to concrete placement.

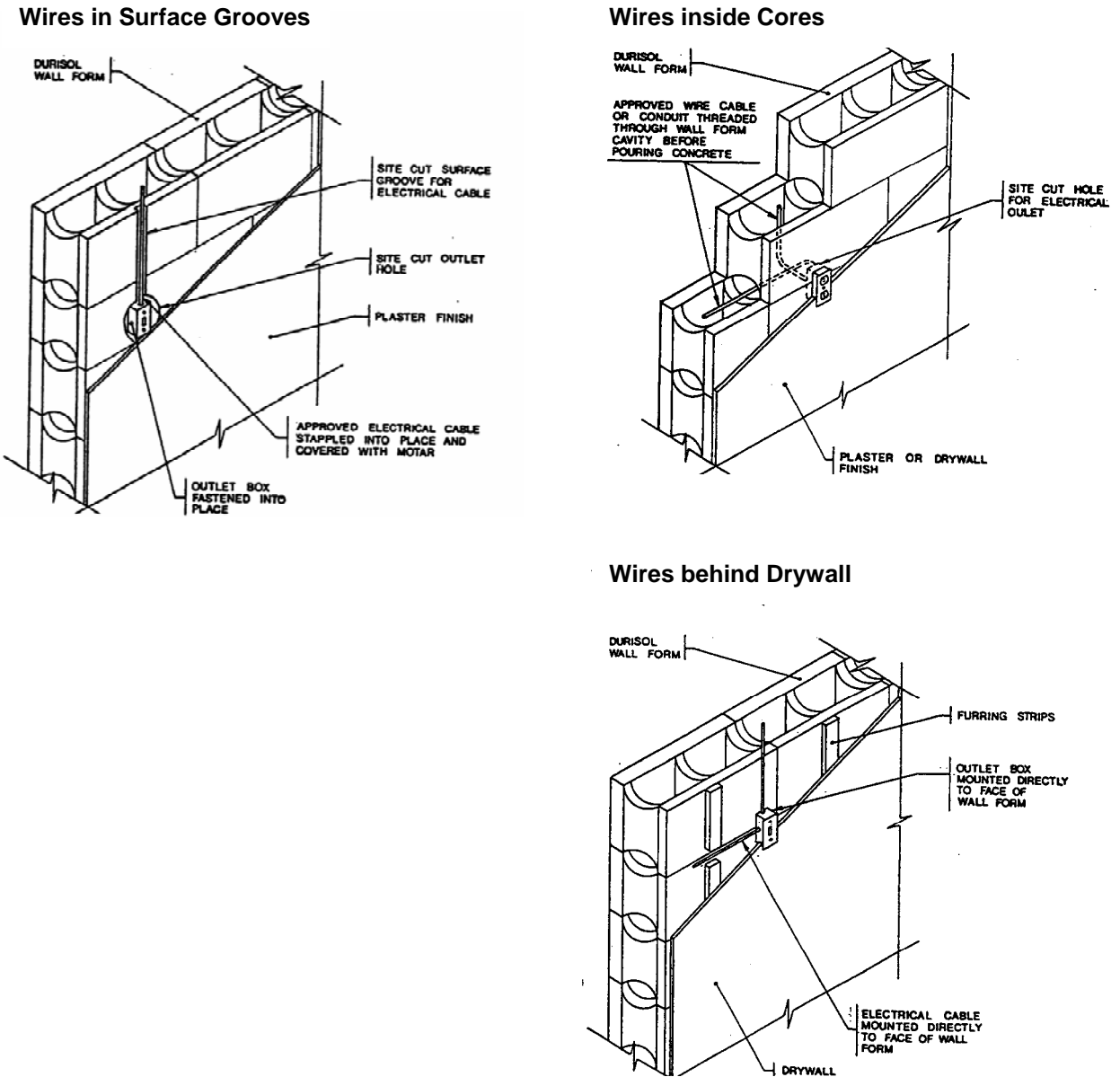

Figure 2.12 – Electrical Service Installation

Service Penetrations such as electrical conduits, water service pipes, air supply, and exhaust ducts can be easily placed by using a standard circular saw, reciprocating saw and/or hole saw. Simply use the saw to cut the Wall Form at the desired location and insert the appropriate service pipe or temporary blocking until the concrete is poured and hardened. The sleeve or conduit at the service penetration will create the void where services can be passed through later.

If penetrations exceed 18" in either height or width, provide standard reinforcing around the opening in the same manner as window openings to prevent cracks from developing at the corners.

2.14 Concrete Placement

Prior to placing concrete in the Durisol Wall Forms, re-check the walls for plumb and make any adjustments necessary. Experience has shown that it is helpful to place a string line at the top perimeter of the wall to aid in adjusting the straightness of the wall prior to, during, and following placement of concrete into the Wall Forms.

Refer to Fill Volume amounts contained in tables 1.2 – 1.5 for estimating concrete quantities. The Fill Volume in these tables is provided in units of yd^3 of concrete per ft^2 of wall surface area to be poured. The SI equivalent of this measure is m^3 of concrete per m^2 of wall area.

All concrete placed within Wall Form units should be in accordance with applicable standards and codes (i.e. ACI 318 or ACI 332 in the USA and CSA A23.1 and CSA A438 in Canada). Also, the concrete used with Durisol should have a minimum strength of 17 MPa (2500 psi) @ 28 days and a **minimum slump of 175mm (7")**. Maximum aggregate size should be 12mm (3/8"). High slump concrete and corresponding higher water to cement ratios are acceptable with Durisol Wall Forms because of the free-draining nature of the material. Once the concrete is placed within the forms, the water within the concrete immediately begins to drain through the Durisol material. This results in easier and faster concrete pouring that ensures a solid wall without voids and without any compromise in strength. Ideally, concrete with a slump between 7" and 9" is recommended for use in conjunction with Durisol.

The insulating properties of Durisol Wall Forms allow winter construction without additional heating or insulation sources being required. Durisol wall systems have been constructed in temperatures as low as 22 °F (- 6°C) without any complication. When pouring in cold temperatures (i.e. less than 46°F or 8°C), the top of the walls must be covered with insulation so that the freshly poured concrete is not exposed to the air.

There are many methods of concrete placement that can be used with Durisol Wall Forms, including but not limited to, conveyor belts, concrete pumps, crane and bucket or directly from truck chute. The concrete pump is typically the method of choice. Although initially more expensive, the extra cost of using a concrete pump will be offset by an easier construction process that results in faster overall construction and reduced labour costs. Placement of concrete by way of pumping should have a hose with a maximum exit nozzle size of 50mm to 80mm (2" – 3.5"). An elbow ("S-hook") at the bottom of the pump is required to slow the flow of concrete before it enters the Wall Form.

Placement of concrete should typically begin by placing concrete below the window and door openings such that when the remainder of the wall is filled, a void is not created below the opening. Following this, the installer should then continue placing concrete into the remainder of the walls from the top and starting beside a window opening or not closer than 3' to a corner. The concrete placement should continue around the building in lifts of not more than four feet per hour.

It is important to monitor the wall alignment relative to the string line installed prior to concrete placement. This will make the job of final alignment much simpler following concrete placement.

As each layer of concrete is placed, care must be taken to ensure proper consolidation of the concrete and that the reinforcing bars are adequately embedded in concrete. Each successive lift must be properly consolidated with the previous pour to ensure that no cold joints occur. The most critical issue affecting the amount of consolidation that is required is the slump of the concrete mix being placed. A lower slump concrete will require additional work to properly consolidate the concrete. Consolidation is best accomplished by hand rodding in conjunction with a high slump concrete. This combination eliminates the unwanted additional form pressure that arises from using a vibrator. If a vibrator is used, the maximum diameter used should be no larger than 1-2" (25-50mm) and care must be taken to ensure the vibrator does not come into contact with the Durisol material.

Once the concrete has been placed, make any final adjustments to the wall alignment to ensure a straight and plumb wall. If continuing Durisol above the present stage of construction, it is recommended that the initial placement of concrete stop 4" to 6" below the top the Wall Form with the surface left rough and unfinished to facilitate a better bond with subsequent lifts. Reinforcement required to bridge cold joints may be specified by shop drawings or by local codes.

When the wall will not be continued for further stages of construction, the concrete will need to be finished at the top of the wall to provide a relatively smooth surface. Typically, the wall will have a wood plate installed in conjunction with anchor bolts to provide attachment for either floor joists, or roof trusses/rafters. Anchor bolts can be placed following finishing of the wall according to local building code requirements for anchorage.

Before the fresh concrete has begun to cure, the wall should be rechecked for plumb and the necessary adjustments made.

3.0 INTERIOR FINISHES

3.1 Gypsum Board

The Durisol material provides a continuous solid surface for attaching interior finishes. Gypsum board can be applied directly to the Durisol material at any location on the surface of the wall. The hard and solid Durisol substrate provides support for the gypsum board and results in a durable and impact resistant finish. This is unlike conventional wall systems in which up to 88% of the wall surface behind the gypsum board is either open cavity, EPS or batt insulation, all of which provide little support for the drywall board and have potential to dent and/or break.

Typically the sheet of gypsum board will be treated with conventional adhesive and screwed to the wall with coarse thread drywall screws. The following table outlines the different types of fasteners and their corresponding allowable pullout strengths while maintaining a minimum safety factor of 3.

Table 3.1 – Fastener Types and Pull-out Loads

Fastener Type	Embedment	Allowable Load (lbf)
#6 x 2" Long Coarse thread drywall screw	1 ¼ "	33
#6 x 2" Long Coarse thread drywall screw	1 ¾ "	37
#8 x 3" Long Wood screw	2 "	52
#12 x 3.5" Long Wood screw	2 "	47

It is recommended that interior drywall be fastened directly to the Durisol Wall Form with standard #6 x 2" long coarse threaded drywall screws as long as the following conditions are met:

- Maximum spacing of fasteners is 16" in the body of the board
- Maximum spacing of fasteners is 8" at the perimeter of the board
- Conventional construction adhesive is employed at 4 corners and center of board
- Caution is taken not to over drill and strip the Durisol material (i.e. use clutch drill).

When choosing adhesives, ensure that they are compatible with the cement-based nature of Durisol. Contact your local adhesive supplier to ensure compatibility.

Another option for fixing gypsum board is to use conventional furring strips that are adhered and screwed to the Durisol material. This is typically done only as a final option to correct Wall Form installation errors.

3.2 Interior Plaster/Stucco

The open textured nature of the Durisol material provides an ideal substrate for stuccos and plasters. Two or three coat applications of plaster work particularly well with no special pretreatment of metal lathe or glass fiber reinforcing being required. When transitioning from dissimilar materials (such as from wood to Durisol, concrete to wood, etc) additional reinforcing may be required. It is also recommended that conventional loose reinforcing fibers be added to the base coat mix to minimize and control cracking of the first coat. Consult your plaster supplier and installer for information regarding the types and quantities of fiber that are generally utilized.

It is important to account for the rough, porous nature of Durisol when estimating finish material quantities. The quantity of base coat material required is approximately 25% higher than that required for conventional concrete masonry. Subsequent coats applied to the base coat will utilize the same amount of material as when used with other conventional wall types such as masonry and wallboard.

For further information, please refer to the separate document outlining the guidelines for using plaster and stucco with Durisol

3.3 Other Interior Finishes

Any finish material can be used with the Durisol wall system. It is important however to consult the finish material manufacturer's installation instructions and specifications and follow all recommended procedures to ensure compatibility with Durisol (i.e. cement-based substrates).

4.0 EXTERIOR FINISHES

The Durisol material is a very durable and weather resistant material and as such can be left exposed without any damage occurring to the material itself. However, since the Durisol material is extremely porous and free-draining, it is important to provide an adequate weather barrier on the exterior surface of Durisol walls in applications where the interior environment must be controlled and protected from moisture and weather.

4.1 Below-Grade Waterproofing

There are many waterproofing products available for basement and other below-grade walls. All conventional waterproofing systems have been successfully used in conjunction with Durisol. Typically a cement based coat is first applied to the below grade Durisol wall surface. The base coat is a simple inexpensive mixture of sand, cement and water (usually 3 parts sand and 1 part cement) that is applied to the Durisol surface to achieve the following purposes:

- It completely seals the exterior surface
- It provides a smooth inexpensive substrate for the next waterproofing layer. By using a parge coat first, the quantity of waterproofing material is reduced which in turn reduces overall costs.

Depending on the soil conditions and water protection systems employed, it is possible to substitute the parge coat with other materials or remove the parge coat altogether. ***This should be done only at the explicit design and instruction of the designer.*** It is always recommended to first apply a cement based parge coat that is followed by other moisture protection systems. The minimal extra cost of this first layer will provide considerable added protection from moisture and increase the redundancy of the waterproofing system.

The other waterproofing products applied to the base coat include (but are not limited to) the following:

- Bitumen-type roll applied damproofing and other “Tar” type materials
- Adhesive backed membranes (“Peel ‘n’ Stick”)
- Drainage layer / Air Gap membranes (Delta MS, Mira-drain, etc.)

The Durisol recommended method of waterproofing is employing a combination of a standard cement parge coat that is followed by the bitumen-based “tar” product or other membrane type of waterproofing. As an added protection, we also recommend the use of the drainage layer type of membrane. This combination of systems provides a redundant waterproofing system that will ensure a moisture-free environment when installed properly.

Please consult the waterproofing product manufacturer for installation procedures when applying their product to a cement-based parge layer (usually the same as procedure as for typical masonry foundation walls).

4.2 Above-Grade Finishes

4.2.1 ACRYLIC BASED COATINGS

Acrylic based coatings are used extensively in North America. A typical EIFS (exterior insulated finish system) system would consist of a wood or masonry wall system that is followed by a layer of EPS foam and then finished with the acrylic based stucco that contains a woven fiberglass mesh that is embedded in the base coat. Since the Durisol wall system provides the integral insulation, no additional EPS is required on the exterior surface. There are many vapour permeable (i.e. breathable) acrylic coatings available that will not compromise the performance of the Durisol wall system with respect to water vapour movement, and the acrylic finish can be applied directly to the Durisol surface. This results in reduced finishing costs as well as providing a solid durable substrate for the stucco and a correspondingly durable and highly impact resistant finish. Also, the Durisol system is hygroscopic (large moisture storage capacity), resistant to rot and damage, and resists mold growth. This means that the problems associated with EIFS systems are not applicable to the Durisol system.

In all circumstances, it is important to follow the EIFS manufacturers recommendations for application of their system to the Durisol wall surface. This will ensure proper moisture protection, eliminate possible defects in the finished installation and guarantee that any warranties offered by the EIFS manufacturer remain valid.

When compared to conventional masonry, the rough, porous nature of Durisol results in 25% more base coat material being required per square foot of wall surface area.

Subsequent coats applied to the base coat will utilize the same amount of material as when used with other conventional walls such as masonry.

For further information, please refer to the separate document outlining the guidelines for using plaster and stucco with Durisol

4.2.2 TRADITIONAL NON-ACRYLIC STUCCO

Unlike the acrylic systems, cement-based and other natural stuccos are extremely dependent on the following:

- Weather conditions at the time application
- Quality of workmanship
- Weather conditions and curing procedures after application
- Preparation of the surface prior to stucco application

It is recommended that traditional cement-based stuccos be used only by experienced, qualified installers who are aware of the implications of the above three items on the performance of the final exterior finish. Consult the installer or material supplier for mix design ratios. The following precautions must be taken with all stucco finishes:

1. When the Durisol material is wet, prior to stucco application, it can expand as much as 0.3% (3mm per 1000mm). As the material dries out, shrinkage of the Durisol material will cause the base coat to crack at the Wall Form joints. This cracking must be allowed to occur and sufficient time must be allowed to let the Durisol material completely dry out prior to applying subsequent coats. The second and third coats are applied to the base coat material that is only slightly wetted so that the Durisol material does not expand and contract too severely.
2. The Durisol surface should be inspected and prepared prior to applying stucco. The ultimate demand for a truly level plaster base is very important because projecting blocks, stones or plates cause irregular plaster thicknesses that are prone to a higher risk of crack formation. The same applies to joints between blocks that are not at all or only partly filled. Joints that are greater than 5 mm (0.2 in) have to be filled with an appropriate material so that they are flush without any thermal bridge. At these joints, the plaster forms a bridge across the open joint. The slightest thermal changes (movement, tension) in the plaster base will cause the plaster to crack. Prior to plastering or precoating, wall surfaces need to be cleaned, any loose pieces need to be removed and replaced with an appropriate material.
3. All stuccos should have reinforcing included in the stucco to minimize cracking in the finish. Both loose fiber reinforcement (polypropylene or glass - typical ½" - ¾" fiber) added to the basecoat and/or manufactured woven fiberglass mesh (manufactured by Dryvit or equivalent) troweled into the base coat may be used (see options below). Conventional self-furring paperbacked expanded metal lath can be used if lath is attached to Durisol with coarse thread screws at maximum 8" spacing, and care is taken not to overdrill the screws or strip the Durisol material. For further information, please refer to the separate document outlining the guidelines for using plaster and stucco with Durisol
4. Woven fiberglass mesh (6oz glass fiber per ft² typical) should be employed in addition to the loose fibermesh fibers in all thermal Wall Forms incorporating insulation inserts. These rolls are the same as used in conventional EIFS systems and are available wherever systems such as Dryvit, Sto, or similar systems are found. Consult the stucco applicator or material supplier for detailed information and specifications for the woven fiberglass mesh.
5. The stucco should be applied in layers not greater than 3/8" thick and must be allowed to cure properly in order to avoid the occurrence of cracks and joint telegraphing. As you

progress from the base coat to the finish coat, each layer should become progressively weaker/softer. The base coat should be the stiffest/hardest coat, while the finish coat should be the weakest/softness coat. This is done to minimize the potential for cracking. For further information, please refer to the separate document outlining the guidelines for using plaster and stucco with Durisol

6. Acrylic additives should also be considered for use with each layer of stucco that is applied to Durisol. In right proportions, these additives increase stucco elasticity and minimize dry-shrinkage cracks without compromising the vapour permeability of the wall system.

For further information, please refer to the separate document outlining the guidelines for using plaster and stucco with Durisol

NOTE:

All information contained in this manual is for general information purposes only. Consult local installers and suppliers of finish material as well as association guidelines (ex. Portland Cement Association guidelines for stucco finishes). Procedures will vary between areas and consideration must be made to items such moisture conditions, exterior/interior temperatures, exposure to wind/drying, etc. It is always the installer's responsibility to ensure quality installation of all finishes.

4.2.3 MASONRY VENEER

Masonry veneer installed against a Durisol wall must be installed in full accordance with local building codes. This includes proper flashing details at the base of the veneer and around all window and door openings as well as other penetrations through the wall. Standard weep holes must also be provided as required by code.

Because the Durisol material is susceptible to deflection under long-term loading, ***masonry veneer cannot be erected directly on top of the Durisol material. All veneers must be supported by solid concrete only.*** Depending on the wall thickness above and below the start of the masonry veneer, three methods of accommodating the veneer are possible (see drawings on following pages):

1. The first method is used when Durisol is employed as foundation walls and not continued behind the masonry veneer, or when a smaller Durisol Wall Form is used behind the masonry veneer. In these situations the tapered Durisol Wall Form can be installed to provide a complete concrete bearing thickness of 8, 10 or 12" (i.e. the full width of the Wall Form).
2. If the Durisol wall system is to be continued behind the masonry veneer, a brick ledge must be created on the exterior of the Wall Form. These brick ledges may be formed and poured integrally with the Durisol wall system at the time of wall construction. There are a variety of products available as brick ledge forms that are manufactured specifically for the ICF industry. Alternately, conventional forming techniques can be utilized to create the brick ledge.
3. The third method of accommodating masonry veneer is using a conventional steel angle that is anchored into the concrete within the Durisol Wall Form. The angle is installed after the wall has been constructed and the concrete has cured. Angle sizes as well as anchor bolt size and spacing must be designed and specified by a local design professional.

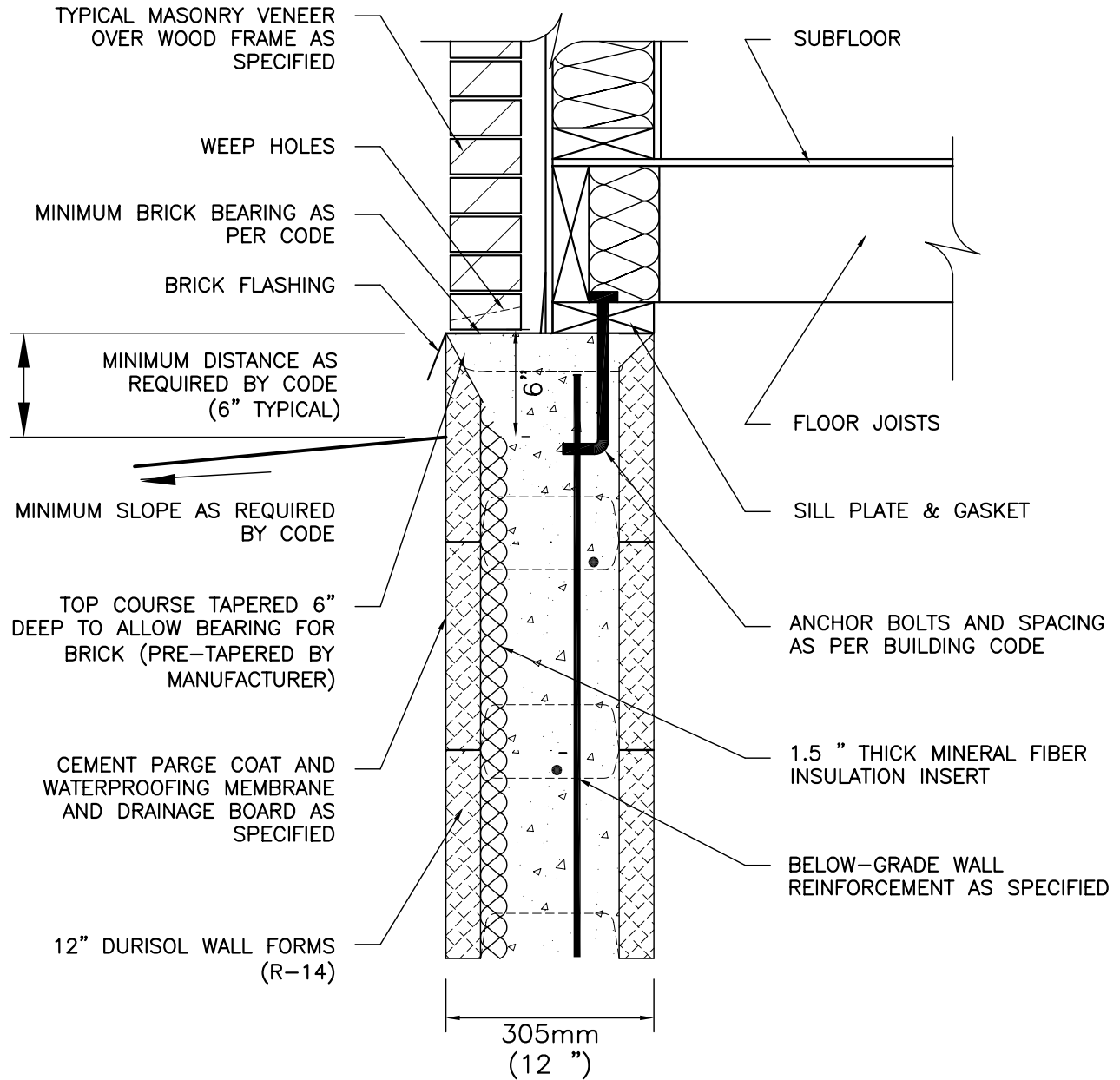

TITLE:
MASONRY VENEER DETAIL (DTG-9)

PROJECT:
TECHNICAL GUIDE

DATE:
08.11.99

REVISED:

DRAWN BY:
BTBH

CHECKED BY:
VA

FILE NAME:
DTG-9

FIGURE:
4.1

SCALE:
1 : 10

DWG. NO:
DTG-9

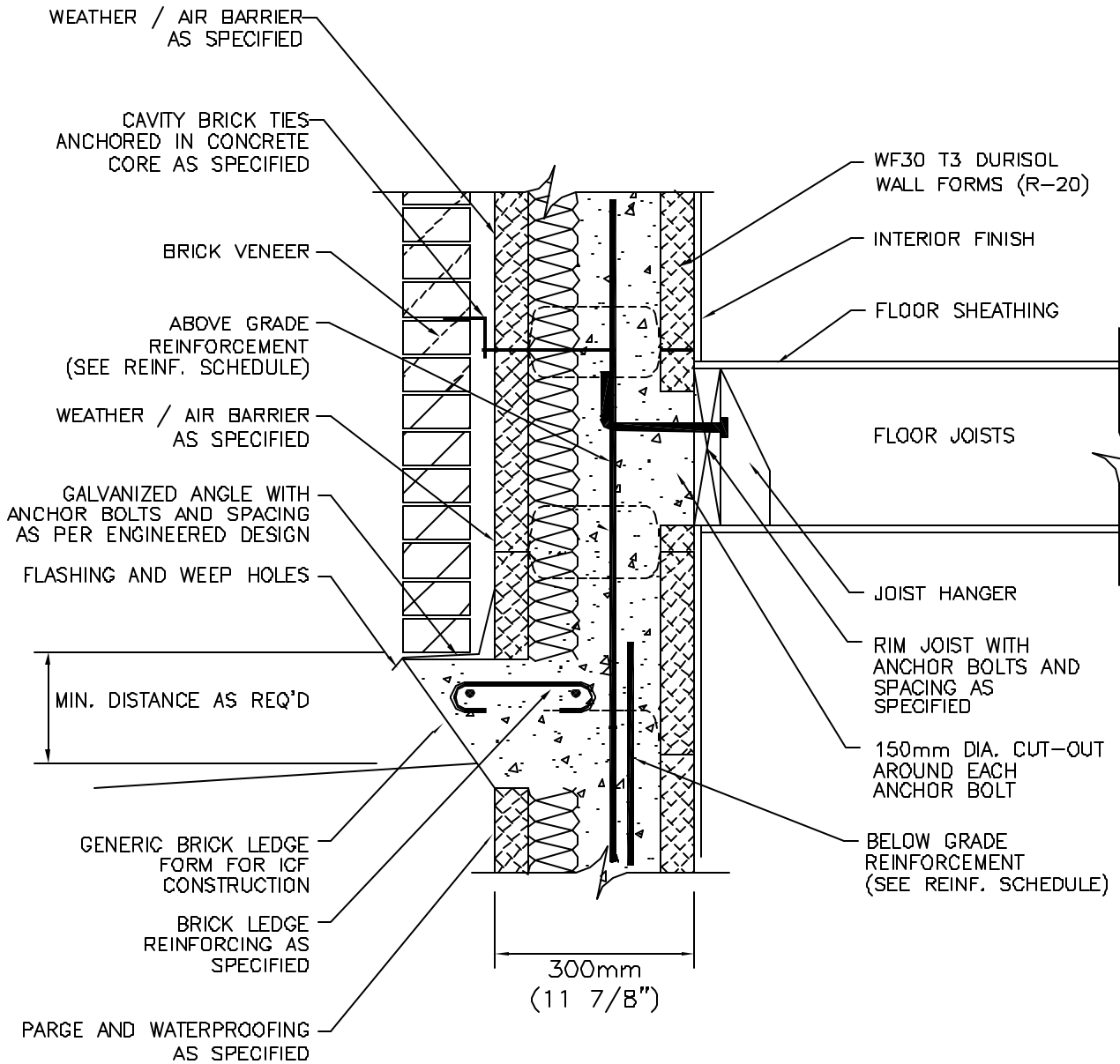

TITLE:
MASONRY VENEER DETAIL (DTG-10)

PROJECT:
TECHNICAL GUIDE

DATE: 08.11.99	REVISED:	DRAWN BY: BTBH	CHECKED BY: VA	FILE NAME: DTG-10
-------------------	----------	-------------------	-------------------	----------------------

FIGURE:
4.2

SCALE:
1 : 10

DWG. NO:
DTG-10

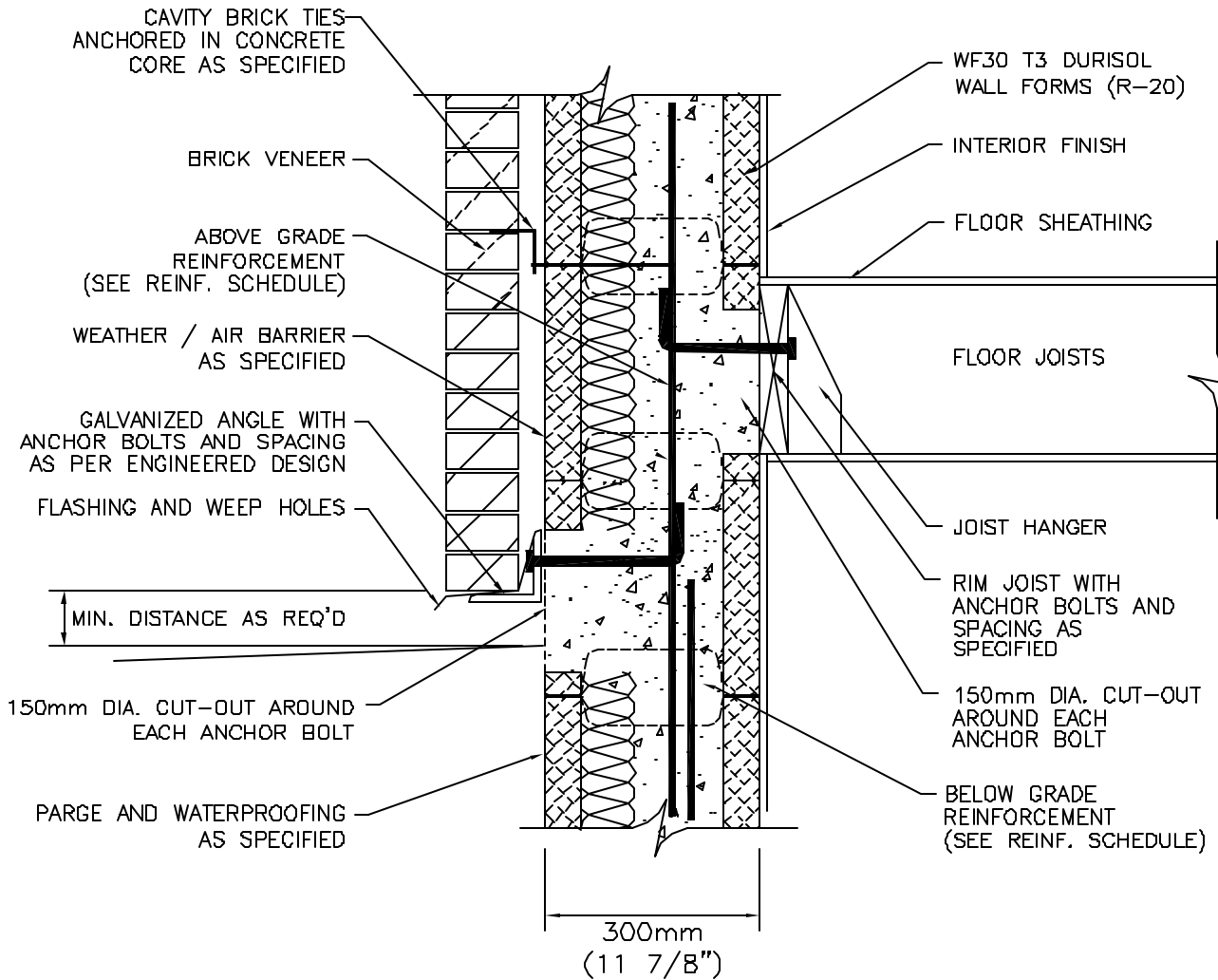

TITLE:
MASONRY VENEER DETAIL (DTG-11)

PROJECT:
TECHNICAL GUIDE

DATE:
08.11.99

REVISED:

DRAWN BY:
BTBH

CHECKED BY:
VA

FILE NAME:
DTG-11

FIGURE:
4.4

SCALE:
1 : 10

DWG. NO:
DTG-11

4.2.4 SIDING

When siding is used in conjunction with the Durisol wall system, it is recommended that strapping first be attached to the Durisol wall surface. All strapping material should be fastened into the concrete core of the wall to ensure the long-term performance of the exterior finish. To facilitate this process, it is recommended to use strapping attachment plates (such as Simpson Strong Tie nail stop NSP 2, Mending Plate MP24, etc) that are screwed through the Durisol and insulation material, into the hollow core of the Wall Form prior to placement of concrete. When the concrete is placed within the core, the concrete will fill around the anchor screws and securely fasten the strapping to the concrete core. This will eliminate the need for labour intensive concrete anchoring methods (Tap-cons, mechanical anchors, etc.) after the wall is erected.

Refer to the drawings on the following pages for detailed information on installation of masonry veneers and siding.

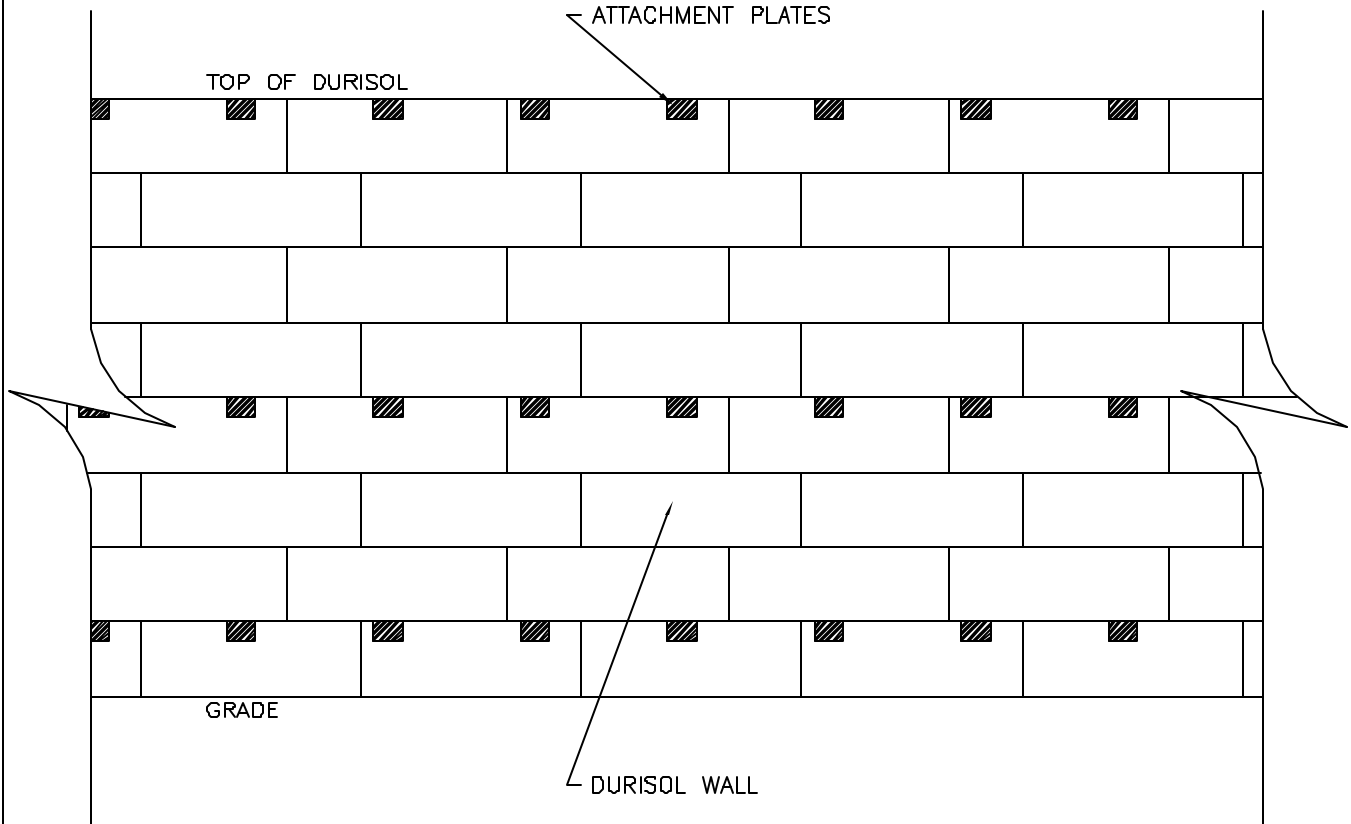

NOTES:

1. ATTACHMENT PLATES ARE NAIL STOP NSP 2 MANUFACTURED BY SIMPSON STRONG TIE OR APPROVED ALTERNATE.
(REFER TO SIDING DETAIL AND PLATE MANUFACTURER SPECIFICATIONS FOR ADDITIONAL INFORMATION)
2. ATTACHMENT PLATES ARE FASTENED THROUGH THE DURISOL MATERIAL AND INSULATION INTO THE HOLLOW CORE PRIOR TO PLACEMENT OF CONCRETE.
3. MAXIMUM VERTICAL SPACING OF ATTACHMENT PLATES IS 1200mm (4'-0") UNLESS OTHERWISE SPECIFIED
4. MAXIMUM HORIZONTAL SPACING OF ATTACHMENT PLATES IS 600mm (2'-0") UNLESS OTHERWISE SPECIFIED

TITLE:
ANCHOR PLATES FOR STRAPPING

PROJECT:
TECHNICAL GUIDE

DATE: 08.11.99	REVISED:	DRAWN BY: BTBH	CHECKED BY: VA	FILE NAME: DTG-12
-------------------	----------	-------------------	-------------------	----------------------

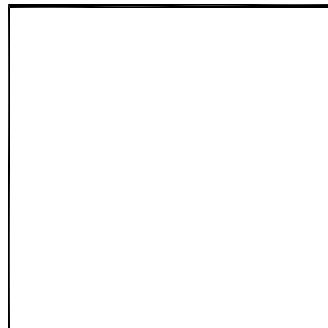
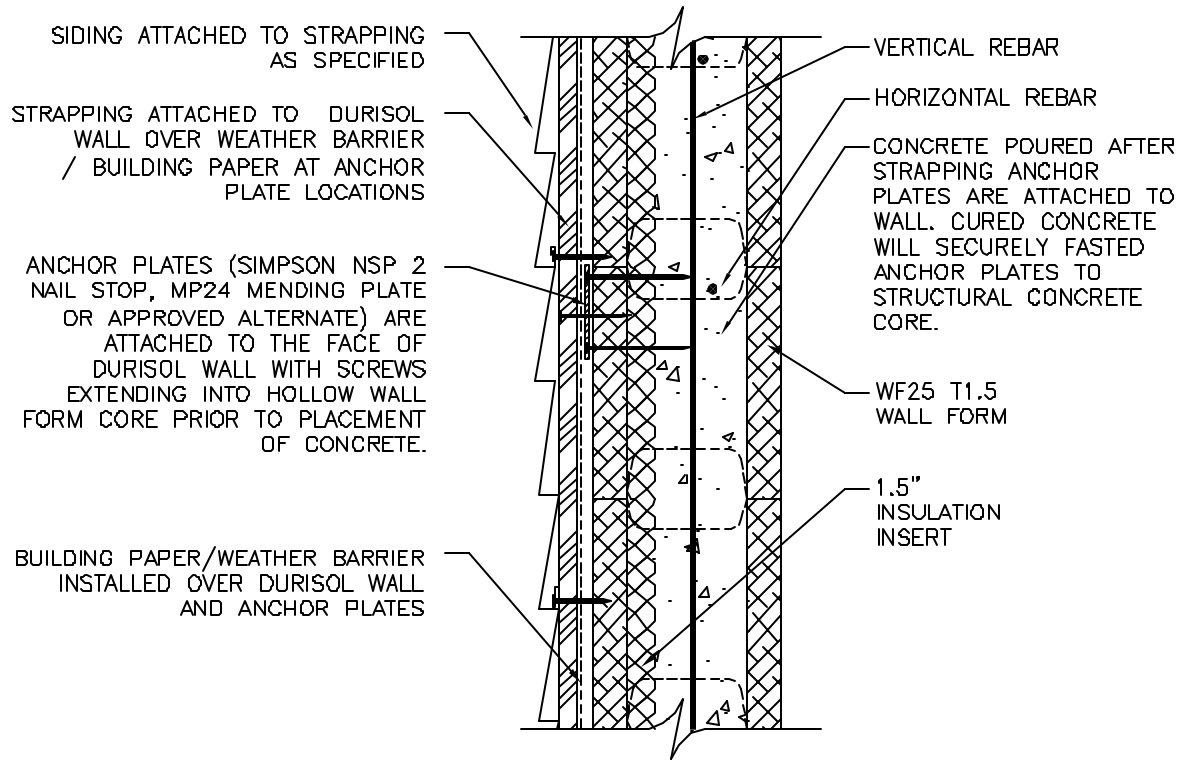

FIGURE:
4.4

SCALE:
NTS

DWG. NO:
DTG-12



SIDING ATTACHED TO STRAPPING AS SPECIFIED

STRAPPING ATTACHED TO DURISOL WALL OVER WEATHER BARRIER / BUILDING PAPER AT ANCHOR PLATE LOCATIONS

ANCHOR PLATES (SIMPSON NSP 2 NAIL STOP, MP24 MENDING PLATE OR APPROVED ALTERNATE) ARE ATTACHED TO THE FACE OF DURISOL WALL WITH SCREWS EXTENDING INTO HOLLOW WALL FORM CORE PRIOR TO PLACEMENT OF CONCRETE.

BUILDING PAPER/WEATHER BARRIER INSTALLED OVER DURISOL WALL AND ANCHOR PLATES

VERTICAL REBAR

HORIZONTAL REBAR

CONCRETE POURED AFTER STRAPPING ANCHOR PLATES ARE ATTACHED TO WALL. CURED CONCRETE WILL SECURELY FASTEN ANCHOR PLATES TO STRUCTURAL CONCRETE CORE.

WF25 T1.5 WALL FORM

1.5" INSULATION INSERT

TITLE:
SIDING ATTACHMENT DETAIL

PROJECT:
TECHNICAL GUIDE

DATE:
08.11.99

REVISED:

DRAWN BY:
BTBH

CHECKED BY:
VA

FILE NAME:
DTG-13

FIGURE:
4.5

SCALE:
1 : 10

DWG. NO:
DTG-13

5.0 AIR-VAPOUR BARRIER REQUIREMENTS

There is considerable confusion in the building industry regarding air barriers, vapour barriers and their respective purposes. The function of a vapour barrier is to prevent moisture and condensation related deterioration of the wall assembly. The function of an air barrier is to prevent heat loss and maintain energy efficiency.

The polyethylene sheet commonly found on the interior of a conventionally framed wall system serves both as an air barrier and a vapour barrier, further confusing the function of the two barriers and their required location within the wall assembly. A vapour barrier is required on the interior of the insulation to prevent the warm moisture laden interior air from traveling through the insulation, to the cool side and condensing within the wall. This is based on winter conditions and a corresponding outward vapour drive. Since the polyethylene sheet serves as both the air barrier and vapour barrier, it is placed on the interior surface to satisfy the requirements for the vapour barrier function. Problems can still occur in this assembly, however, when exterior temperatures are warmer and more humid (summer conditions), resulting in the potential for an inward vapour drive and moisture still condensing within the wall system.

The Durisol wall assembly will typically have a permeance ranging between 40 – 150 ng/(Pa.s.m²), depending on interior and exterior finishes. This is a more vapour permeable wall system than conventional construction. This vapour permeability can actually contribute to improved indoor air quality by providing for more dynamic humidity control - when used in conjunction with hygric mass materials (such as Durisol) and wall components that are not adversely affected by moisture (materials such as concrete and Durisol). This buffering effect is beneficial in reducing large humidity fluctuations within the , by not incorporating a vapour barrier with the Durisol system.

The purpose of an air barrier is simply to prevent air flow through the wall. The location of the air barrier within the wall assembly is not important since the air barrier function is not related to RH and the potential for condensation. As long as the air can not move through the wall, there will be no corresponding heat loss due to air flow, and energy efficiencies are maintained. Consequently, for this purpose, the air barrier can be on the interior or exterior face of the walls system, or even within the wall system itself.

Integral to the desired performance of the Durisol wall system is the inclusion of a continuous air barrier. The majority of thermal performance problems and related moisture / condensation problems, occur as a result of air leakage and not vapour diffusion. The Durisol wall assembly, by itself does not serve as an adequate air barrier and one must be incorporated into the wall assembly. This is typically achieved, by one of the following methods:

- Continuous cement basecoat (Parge coat) applied to the exterior surface of the Durisol material
- Continuous multiple coat exterior stucco systems (synthetic or natural stucco).
- Exterior applied air membrane products
- Exterior building wrap products
- Interior airtight drywall approach (ADA)
- Any other system as outlined by applicable building codes

The following is a list of typical finishes and the corresponding recommended air barriers:

<u>Exterior Cladding</u>	<u>Recommended Air Barrier System</u>
Brick Veneer	Separate air barrier system within air space between Durisol and Veneer. Acceptable air barriers are stucco, parge coat, building paper/wrap, membrane products or any other system meeting the requirements of 2006 OBC air barrier systems.
Exterior Stucco	Stucco is an acceptable air barrier itself and no additional air barrier system is required.
Siding	Separate air barrier system within air space between Durisol and Siding. Acceptable air barriers are stucco, parge coat, building paper/wrap, membrane products or any other system meeting the requirements of 2006 OBC air barrier systems.
Other exterior finish	If the exterior finish can not be shown to act as an adequate air barrier, a separate air barrier system is required between the Durisol and exterior finish. Acceptable air barriers are stucco parge coat, building paper/wrap, membrane products or any other system meeting the requirements of 2006 OBC air barrier systems.

There may be special applications where an interior air barrier is preferable to an exterior air barrier. This is acceptable as long as it has been reviewed and accepted by a licensed professional engineer or architect.